



BiLevel ST 22

Ventilation and Sleep Therapy Device

BiLevel ST 22

Description of unit and instructions for use

Overview

BiLevel ST 22

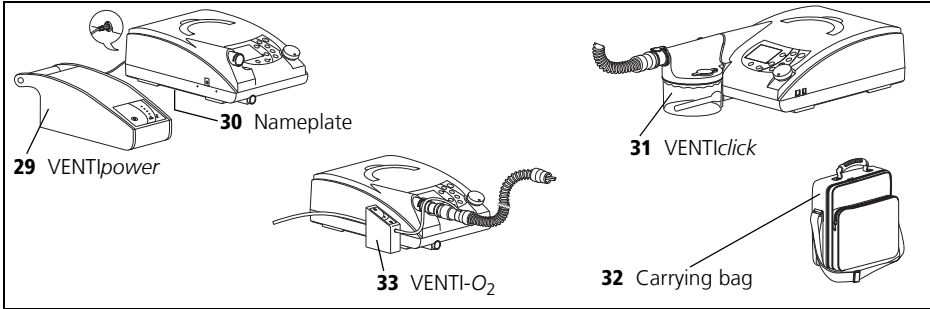
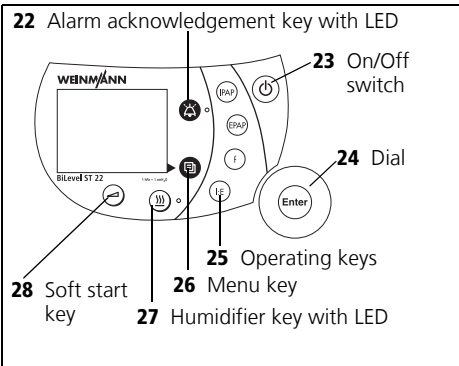
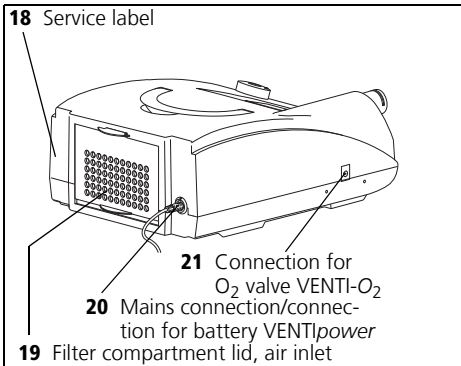
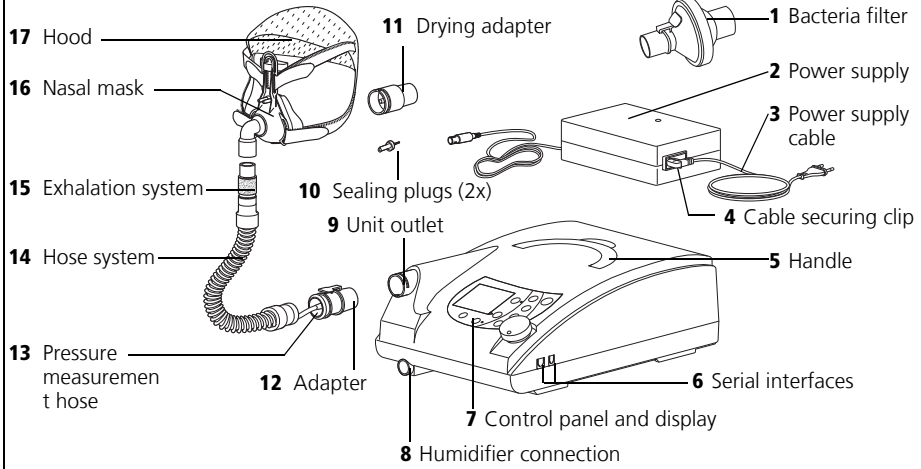

1 Bacteria filter (Accessories)

Used to protect the patient from bacteria, particularly if the unit is being used by a number of patients.

2 Power supply

Used to supply power to the therapy unit.

3 Power supply cable

Connects the power supply to the power supply.

4 Cable securing clip

Prevents accidental disconnection of the unit from the mains supply.

5 Handle

Used for carrying the unit.

6 Serial interfaces

Used to connect to units for visualization and evaluation purposes.

7 Control panel and display

For controlling and monitoring the BiLevel ST 22 and the connected accessories.

8 Humidifier connection

For connecting the humidifier VENTi*click* supplied as an accessory.

9 Unit outlet

The air flows from here via the hose system and nasal mask to the patient.

10 Sealing plugs (2x)

Used to close the pressure measurement hose during cleaning.

11 Drying adapter

Required to dry the hose system with the BiLevel ST 22 and for function check.

12 Adapter

Connects the hose system to the unit outlet.

13 Pressure measurement hose

To measure the pressure in the nasal mask.

14 Hose system

The air flows through the hose system to the mask. The hose system consists of the corrugated tube, pressure measurement hose and adapter.

15 Exhalation system (Accessories)

Exhalation air containing carbon dioxide is diverted here during the therapy.

16 Nasal mask (Accessories)

The nasal mask is used to administer air to the patient at the required therapy pressure.

17 Hood (Accessories)

Helps fit the nasal mask correctly and securely.

18 Service label

The service label shows when the next service is required.

19 Filter compartment lid, air inlet

Covers and securely holds the coarse and fine dust filters.

20 Mains connection/connection for battery VENTi*power*

This is where the connecting cable for the power supply is connected. For connecting mains-independent power supply VENTi*power* supplied as an accessory.

21 Connection for O₂ valve VENTi-O₂

For connecting the VENTi-O₂ oxygen valve (supplied as an accessory).

22 Alarm acknowledgement key with LED

The alarm acknowledgement key temporarily mutes the alarms. The LED provides the visual display of the alarms.

23 On/Off switch

For switching BiLevel ST 22 on and off.

24 Dial

Central operating element of the BiLevel ST 22, used to navigate in the menu.

25 Operating keys

Allows the doctor to make quick settings; disabled in patient mode.

26 Menu key

Used to change from the standard display to the menu and back again.

27 Humidifier key with LED

For setting the humidifier level. Six levels are available. The LED shows whether the humidifier is activated.

28 Soft start key

To activate Soft start and to adjust the Soft start time up to the maximum Soft start time set by the doctor.

29 VENTpower (Accessories)

Available as an accessory, provides a mains-independent power supply for BiLevel ST 22.

30 Nameplate

Provides information about the unit, e.g. serial number and year built.

31 VENTiclick (Accessories)

Available as an accessory, used to humidify and warm the air

32 Carrying bag

For carrying the BiLevel ST 22.

33 VENTI-O₂ (Accessories)

Available as an accessory, used to supply oxygen to the nasal mask.

Standard display during therapy:

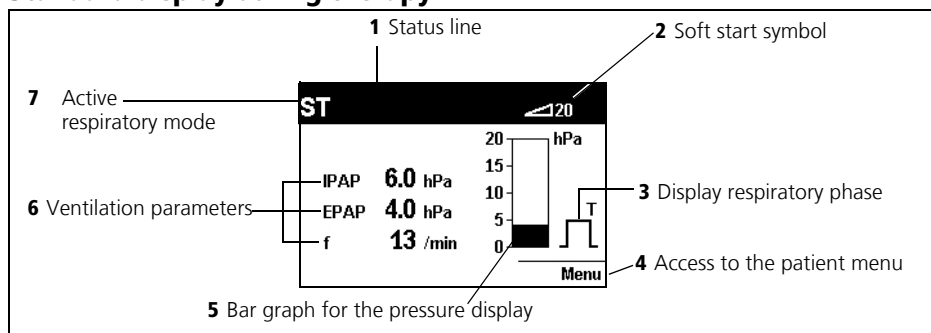

1 Status line

This is where information about the status of the unit is displayed, such as filter change or service due.

2 Soft start symbol

Indicates that Soft start is activated, the number indicates the remaining minutes.

3 Display respiratory phase

Displays whether the current respiratory phase change is spontaneous or mandatory (spontaneous: S, mandatory: T), the display changes according to the respiratory phase from left (inspiration) to right (expiration); in this case mandatory expiration.

4 Access to the patient menu

The key next to this menu item allows you to change to the patient menu and back to the standard display.

5 Bar graph for the pressure display

Displays therapy pressure in graphical form.





6 Ventilation parameters

Depending on the active mode the corresponding current ventilation parameters are displayed.

7 Active respiratory mode

The active ventilation mode is displayed at this point of the status line.

Symbols used in the display

Symbol	Meaning
Status line:	
	Soft start active, remaining time highlighted
	Filter change necessary
	Service required
Main window:	
	Medium priority alarm triggered

Abbreviations used in the display

Symbol	Meaning
Status line:	
S	S mode active
T	T mode active
ST	ST mode active
CPAP	CPAP mode active
Main window:	
IPAP	Inspiration pressure
EPAP	Expiration pressure
hPa	Pressure given in Hectopascal; 1.01973 hPa correspond to 1 cm H ₂ O.
f	Respiratory rate
S	spontaneously triggered switch in respiratory phase
T	mandatory triggered switch in respiratory phase

Symbols and safety tips used in the Operating Instructions:



Warning!

Warns about danger of injury and possible damage to property.

Caution!

Warns about damage to property and possible incorrect therapy results.

Note

Contains useful tips.

Contents

1. Description of unit	7	8.4 Disposal	40
1.1 Intended use	7	9. Scope of supply	41
1.2 User qualification	7	9.1 Standard scope of supply	41
1.3 Functional description	8	9.2 Accessories and spare parts	41
2. Safety instructions	9	10. Technical data	42
2.1 Safety regulations	9	10.1 Pneumatic diagram	45
2.2 Contraindications	11	10.2 Safety distances	46
2.3 Side effects	12	11. Warranty	47
2.4 Special markings on the unit	13	12. Declaration of Conformity	48
3. Setting up the unit	15	13. Index	49
3.1 Positioning and connecting the unit	15		
3.2 Fitting the mask	16		
3.3 Accessories	16		
4. Operation	19		
4.1 BiLevel ST 22 startup	19		
4.2 Activate/deactivate the auto switch-on	20		
4.3 Setting Soft start	21		
4.4 Setting the humidifier	22		
4.5 After usage	23		
4.6 Traveling with BiLevel ST 22	23		
5. Hygienic preparation	24		
5.1 Intervals	24		
5.2 Cleaning	25		
5.3 Disinfection and sterilization	27		
5.4 Multiple patient use	28		
6. Functional check	29		
6.1 Intervals	29		
6.2 Execution	29		
7. Troubleshooting	33		
7.1 Malfunctions	33		
7.2 Alarms	34		
8. Maintenance	37		
8.1 Intervals	37		
8.2 Filter change	38		
8.3 Change the pressure measurement hose	40		

1. Description of unit

1.1 Intended use

Use as a sleep therapy unit

BiLevel ST 22 is a BiLevel unit for treating sleep-related respiratory disorders, i.e. it uses two pressure levels (inspiration = IPAP, exhalation = EPAP) to keep the airways open during sleep. The unit is designed for adult patients with an autonomous respiratory drive. This is in keeping with the following clinical scenarios:

- obstructive, mixed and central sleep-related respiratory disorders, e.g. OSAS, CS and obstructive OHS.

BiLevel ST 22 is **not designed for life-support**.

When used as a sleep therapy unit, BiLevel ST 22 complies with EN ISO 17510-1 (sleep apnea breathing therapy equipment).

Use as a ventilation device

BiLevel ST 22 is a ventilation device for non-invasive ventilation (not for life-support purposes) of adult patients with respiratory insufficiency but capable of breathing autonomously. This is in keeping with the following clinical scenarios:

- restrictive and obstructive ventilation problems, e.g. OSAS, COPD, obesity hypoventilation syndrome
- Problems with the mechanics of breathing, e.g. scoliosis or a chest deformity
- neurological, muscular and neuromuscular problems, e.g. diaphragmatic paresis
- Central respiratory regulation disturbances

BiLevel ST 22 is **not designed for life-support**.

When used as a breathing apparatus, BiLevel ST 22 complies with EN ISO 10651-6 (ventilatory support units).

1.2 User qualification

The settings on BiLevel ST 22 may only be set by a doctor and to suit the individual patient.

When handing over BiLevel ST 22 to the patient, the doctor treating the patient or the clinic staff must instruct the patient on how the unit works.

1.3 Functional description

Preparing the therapy pressure

An electronically controlled fan draws in ambient air via a filter and conveys it to the unit outlet. From here the air flows through the hose system and the nasal mask to the patient.

Sensors recognize the pressure in the nasal mask and in the hose system as well as any respiratory phase change (trigger moment). Accordingly the fan initializes the IPAP and EPAP pressures set by the doctor.

Therapy modes

BiLevel ST 22 can be operated in four therapy modes: S, T, ST, CPAP. Your doctor will set the mode required for your therapy on the unit.

In the time-controlled mode T and the assisted-controlled mode ST your doctor can adjust the respiratory rate to within a range of 6 to 45 breaths per minute and the inspiration time to within a range of 20 % to 67 % of the respiratory cycle.

In the assisted mode S and in the assisted-controlled mode ST your doctor can select one of 6 trigger levels for inspiration and expiration. In the ST mode your doctor can turn the expiration trigger off. Expiration is then time-controlled.

If the patient does not breathe into the unit in the S mode then the pressure is changed to a minimum frequency of 6 breaths per minute.

Other functions

The Soft start function makes going to sleep easier. Your doctor sets the initial pressure for inspiration and expiration, which is then continuously increased during the Soft start phase until the therapy pressure is reached. The doctor can disable this function. Or the doctor can limit the Soft start time.

BiLevel ST 22 has an auto switch-on function. If this is activated, the nasal mask can be turned on by breathing. The unit is turned off using the on/off switch .

On the display the therapy mode and, depending on the mode, the currently applied values for IPAP and EPAP or CPAP and respiratory rate (f) are shown. Further, the spontaneous or mandatory (triggered by the machine) respiratory phase changes are displayed and the pressure change shown graphically.

2. Safety instructions

2.1 Safety regulations

Please read these Operating Instructions through carefully. They form part of the unit and should be available at all times. Only use the unit for the purposes described (see "1.1 Intended use" on page 7).

For your own safety, the safety of your patients, and to comply with the requirements of EU Directive 93/42 EEC, please observe the following:

Operating the unit

Caution!

- The power supply supplied allows the unit to be operated at voltages between 115 V and 230 V. Check that your supply voltage falls within this range.
- Always secure the mains socket on the power supply using the cable securing clip to prevent unintentional removal of the plug.
- BiLevel ST 22 must be connected to an easily accessible socket, so that in the event of a failure, the mains plug can be quickly removed.
- To avoid overheating, do not position the unit near a source of heat or in direct sunlight. Condensation could also form in the VENTiClick humidifier, which then condenses out in the hose system.
- Do not cover the unit with bedding etc. The air inlet would then be blocked and the unit could overheat, resulting in insufficient therapy delivery and damage to the unit.
- Maintain a safe distance between the BiLevel ST 22 and equipment that emits HF radiation (e.g. cell phones) (see page 46). The unit may otherwise malfunction.
- Should the unit fail, an alternative ventilation system should be available on standby.

Caution!

- Third-party masks may only be used after being approved by Weinmann. Using unapproved masks may result in unsuccessful therapy.
- If a pneumotachograph with a high flow resistance is used when starting therapy or for flow checking purposes, this can lead to a limitation of the trigger function of the BiLevel ST 22. If you have any questions please contact Weinmann.

- You must not use antistatic or electrically conductive hoses.
- The use of the VENTi*click* humidifier, bacteria filter and O₂ valve VENTI-O₂ accessories can change the response of the unit. A subsequent addition of one of these accessories may make it necessary to adjust the unit parameters. If necessary ask your doctor.
- Refer to the section "5. Hygienic preparation" on page 24 to avoid infection or bacterial contamination.

Transport/Accessories/Spare Parts/Repair

Caution!

- Do not transport the BiLevel ST 22 with the VENTi*click* humidifier installed. Tilting might cause any water remaining in the VENTi*click* to run into the BiLevel ST 22 and damage it.
- If third-party items are used, functional failures may occur and fitness for use may be restricted. Biocompatibility requirements may also not be met. Please note that in such cases, any claim under warranty and liability will be voided if neither the accessories nor genuine replacement parts recommended in the instructions for use are used.
- Only have inspections and repairs carried out by Weinmann or specialist staff.

Oxygen supply

Warning!



- Smoking and naked flames are prohibited when oxygen is being fed into the air flow. **There is a risk of fire!** The oxygen can become deposited in clothing, bedding or in your hair. It can only be removed by ventilating the room thoroughly.

Caution!

- Feeding oxygen into the air flow is only permitted using the O₂ valve VENTI-O₂, WM 24200.
- Always refer to the Safety Instructions in the guide to your oxygen system.

2.2 Contraindications

The BiLevel ST 22 should not be used if the patient is suffering from one of the following illnesses (or only with particular caution). In each case the decision whether to use BiLevel ST 22 for therapy lies with the doctor in charge.

- Cardiac decompensation
- Severe heart arrhythmia
- Severe hypotension, particularly in conjunction with intravascular volume depletion
- Severe epistaxis
- High risk of barotrauma
- Pneumothorax or pneumomediastinum
- Pneumo-encephalus
- Head injury
- Status after brain operation and surgical procedure performed on hypophysis or on middle or inner ear
- Acute inflammation of the sinuses (sinusitis), middle ear inflammation (otitis media) or perforated eardrum.
- Dehydration

Threatening situations were not observed with BiLevel ST 22.







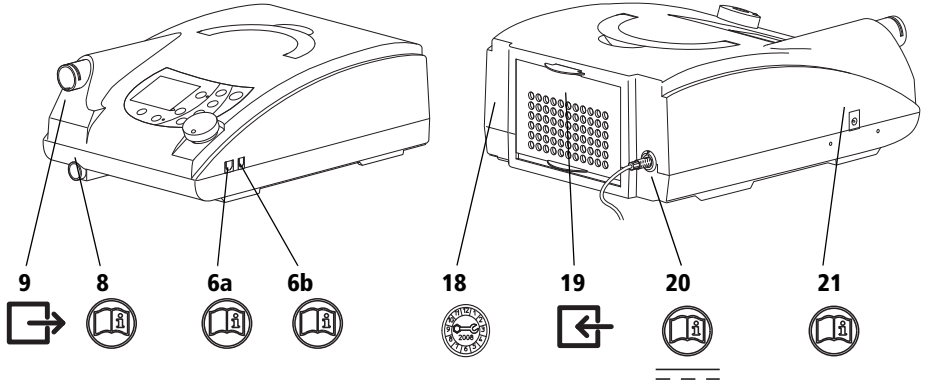

2.3 Side effects

When using BiLevel ST 22 the following undesirable side effects may occur during short-term and long-term usage:





- Pressure points on the face caused by the nasal mask and the forehead padding
- Reddening of the skin on face
- Nasal congestion
- Dry nose
- Dry mouth in morning
- Feeling of pressure in sinuses
- Irritation of conjunctiva of eyes
- Gastrointestinal insufflation of air ("bloated stomach")
- Nosebleeds.

2.4 Special markings on the unit



Front		
9		Unit outlet: emission of ambient air at 4 - 22 hPa
8		Socket: electrical connection for the VENTiClick humidifier, WM 24365; Max. power consumption at 40V: 600 mA
Back		
18		Service label: indicates when the next service is due.
19		Unit inlet: allows air at room temperature to enter
20	 	Voltage supply with power supply WM 24790: 12 V/40 V DC Connection for mains-independent operation with VENTiPower, WM 24100
Side connection sockets		
6a		Connection for adjusting therapy parameters with WEINMANNsupport, WM 93305 or with SOMNOadjust, WM 23930 by specialist staff; Max. power consumption at 12V: 15 mA
6b		Connection for optional supplementary devices such as Analogbox D/A; Max. power consumption at 12V: 25 mA
21		Connection for controlling the O ₂ valve VENTI-O ₂ . Max. power consumption at 12V: 125 mA

Name plate

	Do not dispose of the unit as domestic waste!
	Protection class B
	Type of protection against electric shock: unit of protection class
	Year built
	Refer to Operating Instructions
CE 0197	CE 0197 symbol: Confirms that the product conforms to the applicable European directives
IPX1	Degree of protection against penetration by water (drips)
SN	Serial number of device

3. Setting up the unit

3.1 Positioning and connecting the unit

Set up the unit on a flat surface, e.g. a bedside cabinet or on the floor next to the bed. Keep a distance between the wall and the back of the unit of at least 5 cm, because at the back of the unit there is an air inlet.

Caution!

Do not cover the unit with bedding etc. The air inlet would then be blocked and the unit could overheat, resulting in insufficient therapy delivery and damage to the unit.

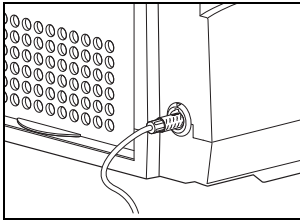

1. Plug the power supply cable into the supply connection of the BiLevel ST 22. Then plug the power supply into a socket outlet (using the power supply cable).

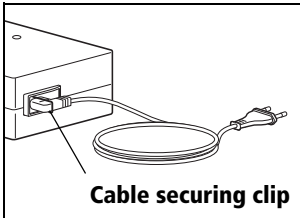

Note

Always secure the mains socket to the power supply using the cable securing clip to prevent unintentional removal of the plug.

2. Connect the power supply cable to a mains socket. The power supply automatically determines the appropriate mains voltage (150 - 230 V). "Weinmann BiLevel ST 22" appears on the display.
3. Insert the hose system adapter into the unit outlet. The unit is now ready to use.

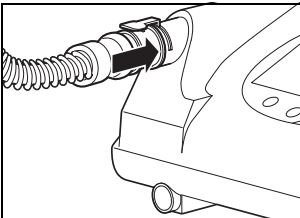

Note:

The appliance automatically compensates for differences in air pressure (e.g. due to high altitude).

3.2 Fitting the mask

BiLevel ST 22 is designed for operation with nasal, oronasal and full face masks. To fit the nasal mask, proceed as follows:

1. Adjust the forehead support (if fitted) of the mask.
2. Connect the headgear to the mask and put the mask on.
3. Adjust the headgear so that there is only a slight pressure from the mask cushion in order to prevent pressure points on the face.

Refer to the Operating Instructions for the respective nasal mask.

3.3 Accessories

Separate exhalation system

A separate exhalation system is necessary if you use a mask without an integrated exhalation system.

The exhalation system allows the used air containing carbon dioxide (CO₂) to escape from the mask. Without an exhalation system the CO₂ concentration would rise to critical values in the mask and hose, thus hindering breathing.

Furthermore, should the unit fail, the exhalation system allows you to breath through the nose or mouth. With full face masks, the patient can breathe through a safety valve on the mask in the event of a malfunction.

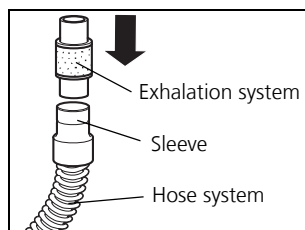

The sleeve at the end of the hose system has a diameter of 19.5 mm and fits over a 22 mm standard conus. Put the exhalation system into the sleeve of the corrugated tube.

Refer to the Operating Instructions for your exhalation system.

Humidifier VENTi**click**

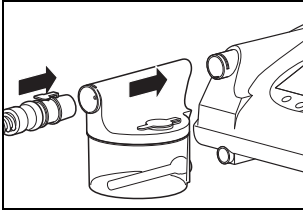

The VENTi**click** humidifier is connected between the BiLevel ST 22 and the hose system. The input connections and the electrical adapter of the heating element must point toward the BiLevel ST 22. Refer to the Operating Instructions for the VENTi**click**.

Oxygen supply with VENTI-**O₂**

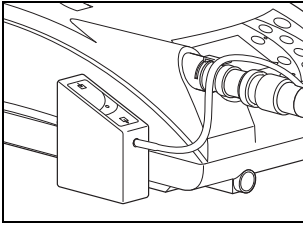

The introduction of oxygen must be administered by the doctor carrying out the treatment.

For safety reasons (fire risk), the direct introduction of oxygen into the breathing hose or the mask without any special protective device is not permitted.

The introduction of oxygen for the BiLevel ST 22 is only permitted using the VENTI-**O₂** oxygen valve. This valve enables up to 4 l/min of oxygen to be introduced. If there is a fault, the VENTI-**O₂** releases the oxygen into the atmosphere. This prevents oxygen accumulating in the unit.

The oxygen can be supplied from an oxygen concentrator (e.g. Oxymat 3), the central gas unit, liquid oxygen as a continuous flow or an oxygen bottle with the appropriate pressure reducer. For flow adjustment purposes, the external oxygen source must be fitted with a device that is independent of the VENTI-**O₂**.

It is essential that you always follow the safety instructions for handling oxygen as well as the Operating Instructions for the VENTI-**O₂** oxygen valve and the oxygen unit used.

Bacteria filter

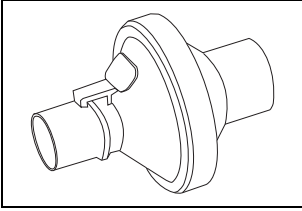

If BiLevel ST 22 is to be used by several patients (e.g. in a hospital), the WM 24148 bacteria filter must be used to protect against infection. It is connected between the hose system and the BiLevel ST 22 or VENTi*click*. Also refer to the Operating Instructions supplied with the bacteria filter.

Caution!

The bacteria filter provides additional resistance to the air flow: This can bring about a change in how the trigger responds. The unit parameters must therefore be adjusted if a bacteria filter is added later.

VENTi*power*

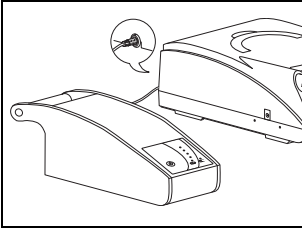

The VENTi*power* is available for mains-independent operation.

VENTi*power* can be connected to the therapy unit as an alternative to the mains supply.

Also refer to the Operating Instructions for the VENTi*power*.

Note

We advise against using the humidifier at the same time as the VENTi*power*, as this considerably reduces the duration of the power supply from the VENTi*power*.

4. Operation

4.1 BiLevel ST 22 startup

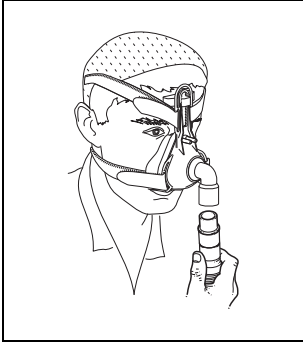

1. If your nasal mask does not have an integrated exhalation system, put the exhalation system onto the end of the hose system (see "Separate exhalation system" on page 16).

Caution!

Always use an exhalation system. Otherwise the CO₂ concentration in the mask and hose would rise to critical values and hinder your breathing.

2. Put the mask on (see "3.2 Fitting the mask" on page 16) and connect the hose system including exhalation system to the nasal mask (plug cone). Please follow the relevant Operating Instructions for the mask and exhalation system.
3. Press the On/Off switch . If auto switch-on is activated, you can also put on the mask and turn BiLevel ST 22 on by breathing (see "4.2 Activate/deactivate the auto switch-on" on page 20).

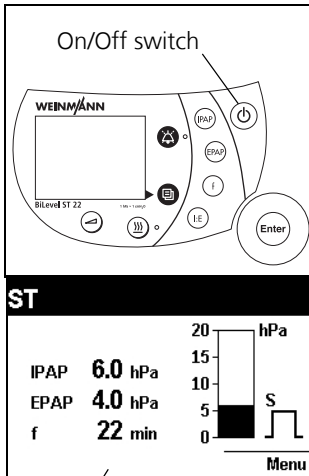



Standard display

The operating hours and the Weinmann software version appear for approx. 3 seconds on the display. The buzzer sounds and the unit begins to feed air through the hose system. The display reverts to the standard display.

The therapy mode that has been set and therapy pressures in hPa (in CPAP mode, CPAP pressure only) are displayed together with the current respiratory rate in l/min.

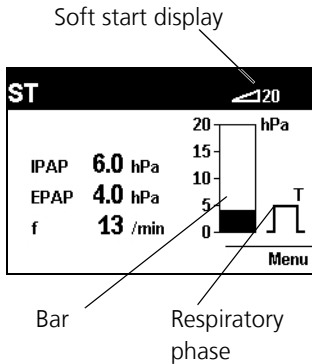
Note: 1.01973 hPa corresponds to 1 cm H₂O.



If Soft start is activated, the Soft start display  appears indicating the remaining Soft start time, a maximum of 30 minutes, or the Soft start time set by the doctor (see "4.3 Setting Soft start" on page 21).

The bar graph shows the pressure levels during inspiration and expiration.

The respiratory phase switch display shows whether the current respiratory phase has been triggered spontaneously by the patient (**S**) or by the machine (**T**). The display changes according to the respiratory phase from left (inspiration) to right (expiration). The diagram shows expiration triggered by the machine.

4.2 Activate/deactivate the auto switch-on

If auto switch-on is activated, you can turn on BiLevel ST 22 using the On/Off switch  or by "breathing". You can only turn off BiLevel ST 22 using the On/Off switch .

Activate auto switch-on

1. Close the hose system or put the mask on.
2. Press the On/Off switch  to turn BiLevel ST 22 on.

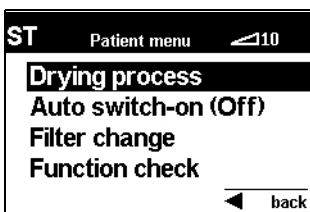

3. Press the Menu key . The patient menu appears on the display. The selection bar is positioned on **Drying process**.

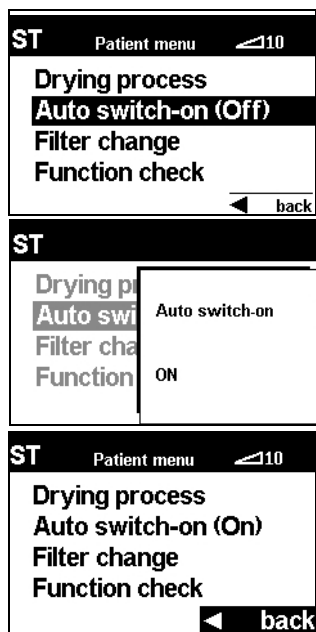

- Using the dial, select the **Auto switch-on (Off)** menu item and press the dial.

The message **Auto switch-on ON** appears for three minutes. The BiLevel ST 22 then reverts to the patient menu. Auto switch-on is now activated.

- Use the dial to quit the patient menu (selection bar on **back** and press the dial) or use the menu key .

If a key is not pressed for 5 minutes, the display reverts to the standard display.

Deactivate auto switch-on



Repeat steps **2.–5.** as described in „ Activate auto switch-on“. If auto switch-on is switched off, you will only be able to turn BiLevel ST 22 on using the key .

4.3 Setting Soft start

If your doctor has enabled the Soft start function, the Soft start time can be selected in 5-minute increments up to a maximum time of 30 minutes. Your doctor can also limit the time to less than 30 minutes. To set the Soft start time, proceed as follows:

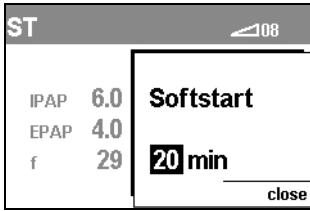
- Close the hose system or put the mask on.



2. Switch BiLevel ST 22 on and press the Soft start key  until the Soft start window appears. Change the Soft start time with the dial (rotate to the right = increase the time; rotate to the left = reduce the time), or press the Soft start key  several times in succession to increase the Soft start time in 5-minute increments. If you press the key again after reaching the maximum time, the unit starts again from the minimum time of 5 minutes.

3. To save the Soft start time, press the Menu key  or the dial. The displayed Soft start time is saved and the Soft start window closes automatically. If a key is not pressed for 4 seconds, the displayed Soft start time will be saved. The settings are retained when the unit is switched off.



Note

BiLevel ST 22 starts automatically in Soft start mode if this was activated when the unit was last used. Soft start can be switched on and off at any time by briefly pressing the Soft start key .

4.4 Setting the humidifier

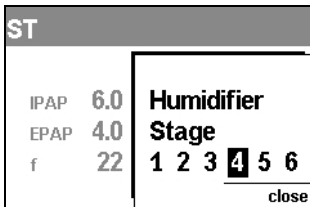
The VENTi*click* humidifier is used to humidify and warm the air prepared by the BiLevel ST 22. There are 6 heating level options. Proceed as follows:





1. Close the hose system or put the mask on.
2. Switch BiLevel ST 22 on and press the humidifier key  until the **Humidifier Stage** window appears. Use the dial to change the heat output (levels 1-6) of the humidifier, or press the  key several times.
3. To save the heat output time, press the Menu key  or the dial. The humidifier level window closes automatically. If a key is not pressed for 4 seconds, the displayed heat output will likewise be saved. The settings are retained when the unit is switched off.

Refer to the Operating Instructions for the VENTi*click*.

Note

- BiLevel ST 22 starts automatically with VENTi*click* active if this was activated when the unit was last used. VENTi*click* can be switched on and off at any time by briefly pressing

the humidifier key . The green status display next to the humidifier key lights up when the humidifier is activated.

- If you press the humidifier key  but a humidifier is not connected, BiLevel ST 22 will not switch this function on.

4.5 After usage

1. Remove the headgear with the nasal mask.
2. Press and hold the On/Off switch for  2 seconds to turn the unit off. The fan switches off and the duration of the last therapy session appears on the display. The unit then switches to standby mode. "Weinmann BiLevel ST 22" appears in the display.

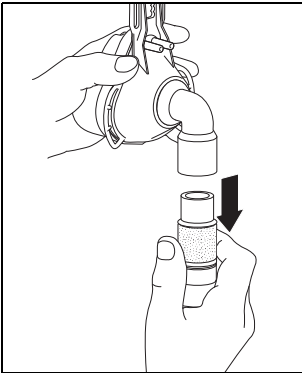

3. Remove the tube connection and if necessary the exhalation system from the nasal mask.
4. Clean the nasal mask and the exhalation system (see "5. Hygienic preparation" on page 24).

Note

To save electricity you can remove the power plug from the outlet socket when not in use. The stored therapy parameters and settings will be retained.

4.6 Traveling with BiLevel ST 22

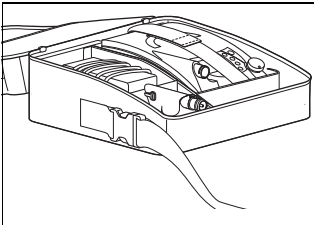

BiLevel ST 22 should only be transported over long distances in the carrying bag provided for this purpose.

Pack the unit, the power supply, the connection cable, the hose system incl. drying adapter, the nasal mask incl. exhalation system and, where applicable, the VENTiClick humidifier and the VENTI-O₂ oxygen valve in the carrying bag. Remember as well to take replacement filters and all the Operating Instructions with you.

If you want to take BiLevel ST 22 with you on a flight, please make sure you are familiar with the necessary regulations before departure. An air transportation certificate can be obtained from Weinmann.

5. Hygienic preparation

This product may contain disposable items. Disposable items are intended to be used only once. So use these items only once and do **not** reprocess them. Reprocessing disposable items may impair the functionality and safety of the product and lead to unforeseeable reactions as a result of ageing, embrittlement, wear, thermal load, the effects of chemical processes, etc.

5.1 Intervals

Check the filters at regular intervals and wipe the housing and filter compartment lid. Head gear (hood and straps) can also be washed if required. Please also observe the following intervals:

Interval	Activity
Daily	<ul style="list-style-type: none">– Clean hose system (see "5.2 Cleaning" on page 25) In accordance with the relevant Operating Instructions:– Clean nasal mask– Clean bacteria filter– Clean exhalation system after each use– Clean humidifier VENTiClick
Every 24 operating hours	<ul style="list-style-type: none">– Change the particle filter in the bacteria filter
Weekly	<ul style="list-style-type: none">– The nasal mask should be cleaned thoroughly in accordance with the Operating Instructions.– Clean the coarse dust filter
Every 1000 operating hours	<ul style="list-style-type: none">– Change the fine filter (Filter Change display ). Sooner if contaminated
Every 6 months	<ul style="list-style-type: none">– Change the coarse dust filter. Sooner if contaminated or worn– Change the pressure measurement hose – sooner if contaminated – (see "8.3 Change the pressure measurement hose" on page 40).
Annually	<ul style="list-style-type: none">– Change the hose system.

5.2 Cleaning

Cleaning the hose system

1. Remove the hose system from the unit and exhalation system.

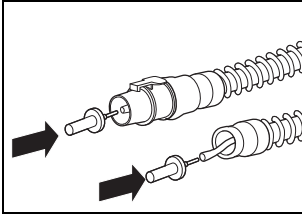

2. Pull one end of the pressure measurement hose out (shake gently if necessary) and seal it with the sealing plug supplied. At the other end, seal off the small opening of the adapter with the second sealing plug so that no water can enter.

3. Using a small amount of detergent in warm water, clean the corrugated tube so no residues remain. Rinse the inside of the hose thoroughly.

4. Rinse the corrugated tube thoroughly both inside and out using clean, warm water.

5. Shake the hose system thoroughly.

6. Hang up the hose system and allow it to drip to prevent moisture from getting into the BiLevel ST 22.



7. Remove the plugs from the pressure measurement hose.

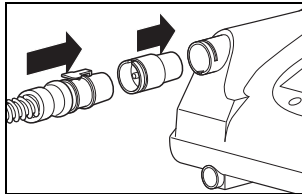

Dry the hose system using BiLevel ST 22

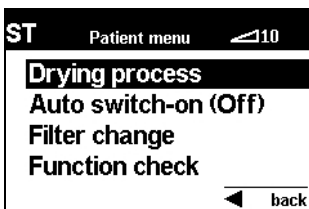

1. If water should accidentally get into the pressure measurement hose, put the supplied red drying adapter into the unit output.
2. Push the adapter of the hose system onto the red drying adapter.



3. Press the On/Off switch  to start the drying process. Use the menu key  to access the patient menu. Press the dial to start the drying process. The unit will now dry the hose system.

The remaining drying time is displayed. After 30 minutes BiLevel ST 22 automatically switches off. You can interrupt the process at any time by pressing the Menu key  or the On/Off switch  for 2 seconds. If the hose system is still damp in places after drying, repeat the process.

4. Remove the drying adapter from the unit outlet.

Cleaning the BiLevel ST 22-housing

Warning!



Risk of electric shock! Before cleaning, disconnect the power supply cable from the power input of the BiLevel ST 22 and the mains plug from the socket.

- Make sure no liquid gets into the unit. Never immerse the unit in disinfectant or any other liquid. This can damage the unit and consequently endanger users and patients.

1. Wipe down the unit, the power supply and the power supply cable with a damp, soft cloth. The BiLevel ST 22 must be completely dry before starting up.

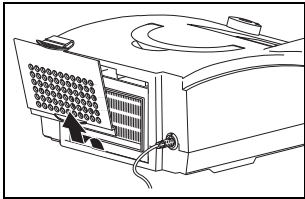

2. Remove the filter compartment lid.
3. Remove the coarse dust filter as described in 8.2.
4. Clean the filter compartment lid with fresh running water until it is free from residue. Then dry carefully.
5. Reinsert the coarse dust filter and the filter compartment lid as described in 8.2.

Cleaning the coarse dust filter/changing the fine filter

1. Remove the filter compartment lid again as described in 8.2.
2. Remove the coarse dust filter from the filter compartment lid and clean it under clear running water until no residue remains.
3. Change the fine filter if necessary.
4. Let the coarse dust filter dry. Before start up, the coarse dust filter must be completely dry.
5. Reinsert the coarse dust filter and close the filter compartment lid.

Note:

The fine filter cannot be cleaned. It has to be changed every 1000 operating hours as described in 8.2

Accessories

To clean the exhalation system, the nasal mask, the headgear VENTIpower, VENTI-O₂, the bacteria filter and VENTIconnect please refer to "Hygienic Preparation" in the relevant Operating Instructions.

5.3 Disinfection and sterilization

If necessary, for example after an infectious illness or if the unit has become unusually contaminated, you can also disinfect the housing, the power supply and cable, the hose system, the bacteria filter housing, VENTi*click*, VENTI- O_2 and VENTI*power*. Refer to the Operating Instructions for the disinfectant used. We recommend that you wear suitable gloves when disinfecting the equipment (e.g. household or disposable gloves).

Unit

The housing, power supply and power supply cable of the BiLevel ST 22 are cleaned by being simply wiped over with disinfectant. We recommend TERRALIN[®].

Hose system

As a disinfectant we recommend GIGASEPT FF. Carry out the same steps when using GIGASEPT FF as described under "Cleaning".

After disinfecting rinse all the parts thoroughly with distilled water. Let the parts dry out completely.

Let the hose system drip-dry. Dry the hose system and BiLevel ST 22 as described in 5.2.

- The corrugated tube WM 24130 (transparent) can be cleaned in warm water up to 70 °C. Sterilization is not permitted.
- The corrugated tube WM 24120 (gray) can be steam-sterilized in units complying with EN 285. Temperature: 134 °C, minimum hold time 3 minutes. Please observe EN 554 or ISO 11134 with respect to validation and monitoring.

Accessories

To disinfect or sterilize the exhalation system, the nasal mask, VENTI*power*, VENTI- O_2 , the bacteria filter and VENTi*click*, refer to the Chapter "Disinfection and Sterilization" in the relevant Operating Instructions.

5.4 Multiple patient use

If the unit is operated **with** bacteria filters:

- Change the bacteria filter.
or:
- Sterilize the bacteria filter and change the particle filters located inside.

If the unit is operated **without** bacteria filters:



- have the unit subjected to hygienic preparation by a dealer on change of patient.

6. Functional check

6.1 Intervals

Implement a functional check at least every 6 months. If you find a defect during the functional check, do not use BiLevel ST 22 until the defect has been remedied.

6.2 Execution

1. Assemble BiLevel ST 22 with the hose system, exhalation system and power supply cable ready for operation.
2. Close the opening of the hose system, e.g. using your thumb or hand.
3. Turn the unit on by pressing the on/off  switch.
4. If Soft start is switched on, switch it off by pressing the Soft start key .

Then, depending on the operating mode set, check the following functions:

Function: / Mode:	CPAP	S	T	ST
Pressure accuracy	•	•	•	•
Respiratory rate/minimum frequency	–	•	•	•
Triggering	–	•	–	•
Soft start	•	•	•	•
Flow sensor	–	•	•	•
Alarms	•	•	•	•

If the values or functions specified below are not met, please send the unit for repair to the dealer or to Weinmann.

Pressure accuracy

1. Wait for approx. 1 minute, then read the CPAP pressure on the display or the IPAP and EPAP pressure readings on the bar graph and check whether the values displayed correspond to the prescribed values.

Respiratory rate/minimum frequency

Note

This check is unnecessary if the device is operated in CPAP mode.

1. Please observe the following procedure: the unit switches periodically between the two pressure levels IPAP and EPAP.
2. Count the IPAP phases within one minute and compare them with the display. You can recognize the IPAP phase by the louder operating noise or by the bar graph in the standard display.

Desired values:

- S mode: 6 phases a minute
- T and ST mode: prescribed value



Permitted deviation:

- maximum ± 1 phase a minute

Triggering

Note

This check is only necessary if the device is operated in the S or ST modes.

1. Turn the unit off by pressing and holding the on/off switch  for 2 seconds.
2. Assemble the nasal mask.
3. Turn the unit on by pressing the on/off switch .
4. Put the nasal mask on and breathe normally. In the ST mode your breathing frequency must be above the prescribed frequency so that the unit's time-controlled trigger is not active.

The unit must respond to the change in breathing phases with the change in pressure level.

Note

If the expiration trigger is not functioning, it may have been turned off. Ask your doctor if this is the case.

Soft start

Note

This check is unnecessary if Soft start has been disabled by the doctor.



1. Turn Soft start on by pressing the Soft start key .

The Soft start display  appears and the Soft start time is displayed.

Flow sensor/Pressure sensor

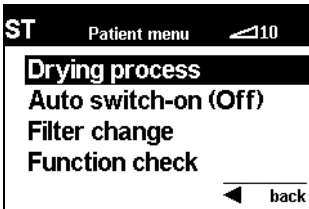
1. Plug the supplied red drying adapter into the unit outlet.



2. Press the on/off switch  to start the functional check for the flow sensor. Use the menu key  to access the patient menu.

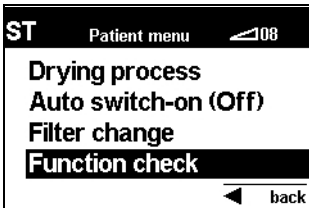

3. Using the dial, slide the black selection- bar to **Function check** and press the dial.

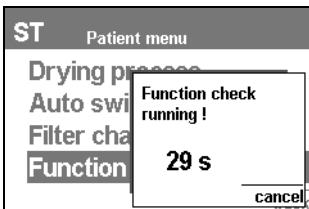

A window opens with the message "Function check running!". The remaining duration of the functional check is displayed.

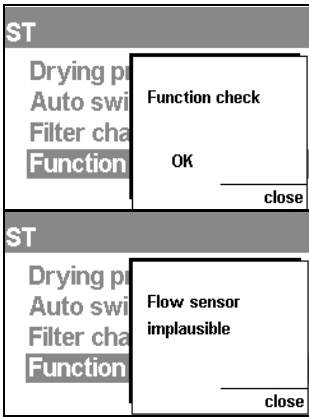

- When the functional check has finished, the message "Function check OK" appears and BiLevel ST 22 reverts to the standard display.

If a plausibility error is found during the functional check, the message "Flow sensor implausible!", "Sensors implausible!" or "Implausible pressure measurement!" appears.

Close the window using the menu key , turn the BiLevel ST 22 off and disconnect the power for 5 minutes. Check whether the drying adapter has been fitted correctly. Repeat the functional check.

If the message "Flow sensor implausible!", "Sensors implausible!" or "Implausible pressure measurement!" appears again, please contact Weinmann or your dealer immediately to have your unit repaired.

Alarms

BiLevel ST 22 carries out a  self-test on the sensors when the on/off switch is pressed. The alarm feature is also tested. If an error occurs during the self-test, an error message appears on the main screen (see also "7. Troubleshooting" on page 33).

- Check the buzzer and the status displays:

Each time you turn the BiLevel ST 22 on, check that you can hear the buzzer and that the status display lights up.

- Check the power failure alarm:

Start BiLevel ST 22. Now pull the power supply cable out of the socket; the display goes out and the buzzer sounds.



Note



BiLevel ST 22 must have been connected to the mains for at least 5 minutes before carrying out the test.

Turn the unit off after the functional check has been completed by pressing the on/off  switch.

7. Troubleshooting



7.1 Malfunctions

Malfunctions/ Malfunction message	Cause	Rectification
No operating sound, Nothing on the display	No supply voltage available.	Check that power supply and power supply cables are securely connected. Check outlet is working by connecting another piece of equipment (e.g. a lamp).
Unit cannot be switched on by breathing.	Auto switch-on not activated	Activate auto switch-on (4.2, page 20).
Soft start cannot be switched on	The Soft start function is disabled	Check with your doctor as to whether the Soft start function can be enabled for your treatment.
Soft start time cannot be set to 30 minutes	Maximum Soft start time has been limited by the doctor	Check with your doctor whether the maximum Soft start time for the current therapy session can be extended to 30 minutes.
Unit is running but does not reach selected IPAP pressure level.	Filter soiled.	Clean/change filter (8.2, page 38)
	Mask not airtight.	Adjust the headgear so that the nasal mask fits snugly, or replace it if necessary
	Nasal mask is defective.	Replace nasal mask
 Please change the filter!	Filter soiled.	Press the alarm acknowledgement key, Clean/change filter as quickly as possible (8.2, page 38)
Filter change indicator  appears		Clean/change filter as quickly as possible (8.2, page 38)

Malfunctions/ Malfunction message	Cause	Rectification
 Battery dead	Unit's internal battery is discharged	Press the alarm acknowledgement key, have the battery replaced by a dealer so that the therapy session can be correctly recorded.
 Clock is not set	Internal clock of the BiLevel ST 22 is not set	Press the alarm acknowledgement key and have your doctor set the clock so that the therapy session can be correctly recorded.
Service display  appears		Unit must be checked or serviced by Weinmann or a dealer as soon as possible.

If there are defects that cannot be rectified at once, please contact Weinmann or your dealer immediately to have the unit repaired. To avoid greater damage, do not use the unit.

7.2 Alarms

The BiLevel ST 22 only issues medium priority alarms. These are indicated by the symbol   in the alarm window, a **flashing** yellow status display and an acoustic alarm (buzzer).

Acknowledging alarms

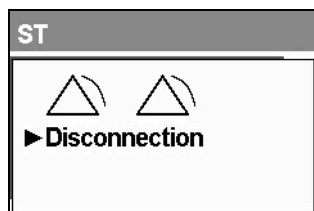

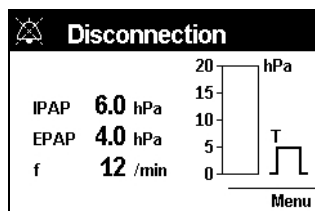

If an error triggers an alarm (here: disconnection alarm), press the alarm acknowledgement key . The acoustic alarm is muted for about 120 seconds.





The standard display appears again after acknowledging the acoustic alarm. If the fault has not been rectified, the status line continues to be displayed and the yellow status display flashes (or is illuminated) until the fault is cleared.

If the fault has not been rectified within 120 seconds of acknowledgement, the acoustic alarm (buzzer) sounds again.

Assistance with rectifying faults can be found in the following tables.

Display	Alarm	Cause	Rectification
Pressure measurement hose disconnected (DMS)! 	Medium priority	The pressure measurement hose was not correctly fitted or was forgotten during fitting	Check that the hose is present and has been correctly fitted
Unit failure!  Excess pressure	Medium priority	Defective pressure sensor	Have the unit repaired
	Pressure measurement hose blocked. Medium priority	Water droplets in the pressure measurement hose	Dry the pressure measurement hose as described in 5.2
Disconnection! 	Medium priority	Hose system is not correctly fitted to the unit or not fitted at all	Check the hose connection on the unit
		The unit is being operated with an open mask (not fitted).	Put the mask on, or turn the unit off.

Display	Alarm	Cause	Rectification
Unit failure!  Excess temperature	Medium priority	Overheating of the unit due to direct sunlight	Let the unit cool down and find a more suitable place to locate it.
	Medium priority	The unit was operating outside the permitted temperature range	
Display vanished	Acoustic signal for at least 120 seconds, no display visible. Medium priority	No mains voltage available	Check that power supply and power supply cables are securely connected. Check outlet is working by connecting another piece of equipment (e.g. a lamp)
		The battery VENTIpower is discharged.	Remove the VENTIpower from the BiLevel ST 22 and recharge. Continue operating BiLevel ST 22 using a mains socket.
Unit failure!  Code	Medium priority	Problems with electronics or running the program.	Disconnect power and reconnect. Turn the unit on again
		Water droplets in the pressure measurement hose	Dry the pressure measurement hose as described in 5.2
		Sealing plugs still on pressure measurement hose after hygienic preparation.	Remove both sealing plugs. Disconnect power and reconnect. Turn the unit on again without the hose system.

If there are defects that cannot be rectified at once, please contact Weinmann or your dealer immediately to have the unit repaired. To avoid greater damage, do not use the unit.

8. Maintenance

8.1 Intervals

We recommend that repairs are only carried out by Weinmann or by authorized dealers.

Both filters must be regularly checked for contamination.

- Clean the coarse dust filter once a week and replace it at least every 6 months.
- The fine filter must be changed at the latest after 1000 operating hours (filter change symbol  appears on the display).

For hygiene reasons, we recommend that the following parts be changed at the stated intervals:

- Pressure measurement hose every 6 months – sooner if contaminated
- Complete mask system depending on contamination, every 6 to 12 months
- Exhalation system according to the relevant Operating Instructions

As a preventative measure, maintenance must be carried out at the following intervals:

- Every 5000 operating hours (maintenance symbol  appears in display)
- At the latest after 2 years (see maintenance label on the back of the device)

We recommend that repairs are only carried out by Weinmann or by authorized dealers.

Maintenance include:

- Check for completeness
- Visual inspection for mechanical damage
- Filter change
- Cleaning the unit
- Replacement of any defective parts
- Complete check of unit functions and pressure displays
- Battery change
- Final test according to test instruction WM 24954

8.2 Filter change

Change coarse dustfilter

Only use original Weinmann filters. Claims under warranty will be forfeited if filters from outside manufacturers are used; these may also restrict function and biocompatibility.

1. If the humidifier VENTiClick is connected, first disconnect it from the unit. This prevents water running into the unit during a filter change. Refer to the Operating Instructions for the VENTiClick.

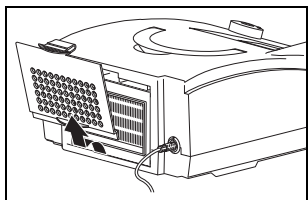

2. Press on the lock of the filter compartment lid and remove the lid.

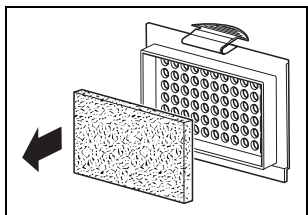

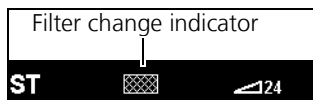

3. Remove the coarse dust filter from the filter compartment lid and dispose of it as normal domestic waste.
4. Insert the clean coarse dust filter into the filter compartment lid.
5. Then put the filter compartment lid lower edge first into the encasing section. Then press the filter compartment lid into the housing until it locks into position.

Change the fine dustfilter



The fine dust filter must be changed when it becomes dark and discolored and at least every 1000 operating hours. In the latter case the message "Please change filter" appears on the display when the unit is turned on.

Acknowledge the message by pressing the alarm acknowledgement  key. The change filter symbol then remains  in the status line. To change the fine filter, proceed as follows:

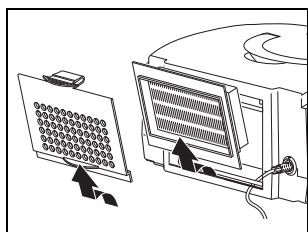

1. Press on the lock of the filter compartment lid and remove the lid.
2. Replace the fine filter with a new fine filter WM 15026. Dispose of the old filter in the normal domestic waste.
3. Then put the filter compartment lid lower edge first into the encasing section. Then press the filter compartment lid into the housing until it locks into position.

Reset the filter change display

After you have changed the fine filter, you must reset the filter change display. This is also necessary if the filter has been changed before the 1000 operating hours have elapsed, in which case the filter change symbol does not appear in the display.

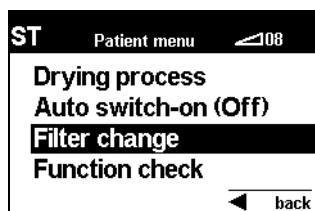

1. To reset the filter change display, press the menu key when the device is switched on and, using the dial, select the **Filter change** item in the Patient Menu. Press the dial to call up the "Filter Change" menu.



2. The "Reset filter change?" prompt appears. Using the dial, select **YES** and confirm by pressing the dial.

To cancel the process, select **NO** and press the dial. The process will be canceled.

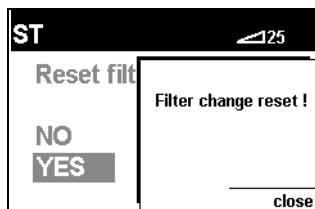

If you have selected and confirmed **YES**, the message "Filter Change reset" appears for 3 seconds.

Bacteria filter

When using the bacteria filter WM 24148, change the particle filter in the bacteria filter in accordance with the relevant Operating Instructions.

8.3 Change the pressure measurement hose

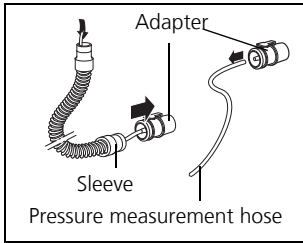

1. Remove the sleeve of the corrugated tube from the adapter.
2. Pull the pressure measurement hose out of the corrugated tube.
3. Pull the pressure measurement hose away from the adapter.

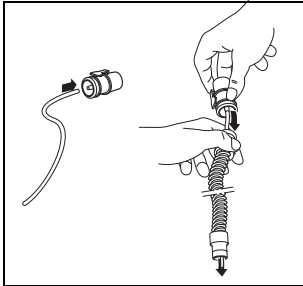

4. Put the new pressure measurement hose onto the adapter.
5. Hold the corrugated tube up and introduce the free end of the new pressure measurement hose.
6. Push the sleeve of the corrugated tube onto the adapter.
7. Dispose of the old pressure measurement hose.

8.4 Disposal



Do not dispose of the unit as domestic waste. To dispose of the unit properly, please contact a licensed and certified electronic waste recycler. Names and addresses can be obtained from your Environmental Officer or municipal authorities. The unit packaging (cardboard box and inserts) can be disposed of as waste paper.

9. Scope of supply

9.1 Standard scope of supply

BiLevel ST 22

WM 27500

Parts	Order number
BiLevel ST 22 Basic unit	WM 27510
Hose system	WM 24130
Drying adapter	WM 24203
Carrying bag	WM 24995
Power supply cable	WM 24177
Power supply	WM 24790
Coarse dust filter	WM 24880
Fine filter, packed	WM 15026
Operating instructions BiLevel ST 22, GB	WM 66131
Patient record	WM 66165

9.2 Accessories and spare parts

You can order accessories and spare parts separately if required. A current list of accessories and spare parts can be ordered on the Internet at www.weinmann.de or via your dealer.

10. Technical data

	BiLevel ST 22	BiLevel ST 22 with VENTiClick
Product class as per EU Directive 93/42/EEC	IIa	
Dimensions WxHxD in cm	23 x 12 x 28	23 x 12 x 39.5
Weight	approx. 3.7 kg	approx. 4.0 kg
Temperature range – Operation – Storage	+5 °C to +35 °C –40 °C to +70 °C	
Air pressure range	600 – 1100 hPa (allows for operation in an altitude of up to approximately 4000 meters) automatic altitude compensation	
Electrical connection	115 – 230 V AC, 50–60 Hz Tolerance -20 % to +10%	
Power consumption during – Operation – Standby	230 V 0.15 A 0.043 A	115 V 0.3 A 0.068 A
Classification as per EN 60601-1 – Protection against electric shock – Type of protection from electric shock – Protection against damaging ingress of water	Protection class II Type B IPX1	
Electromagnetic compatibility (EMC) as per 60601-1-2 : 2007: – Radio shielding – Radio interference suppression	EN 55011 EN 61000-3-2, EN 61000-3-3, EN 61000-4-2 up to 6, EN 61000-4-8, EN 61000-4-11	
Average sound pressure level according to EN ISO 17510-1:2009	approx. 32 dB (A) at 20 hPa approx. 30 dB (A) at 15 hPa approx. 28 dB (A) at 12 hPa approx. 26 dB (A) at 10 hPa (corresponds to a noise level of 34 dB (A)) approx. 24 dB (A) at 7 hPa	
Sound pressure level, alarm warning	at least 62 dB (A)	

	BiLevel ST 22	BiLevel ST 22 with VENTIclick
IPAP pressure range EPAP pressure range CPAP pressure range Pressure accuracy Increment	6 to 22 hPa 4 to 20 hPa 4 to 20 hPa ±0.6 hPa 0.2 hPa (1 hPa = 1mbar ≈ 1 cm H ₂ O)	
Minimum stable limit pressure (PLS _{min}) (min. pressure if there is a fault) Maximum stable limit pressure (PLS _{max}) (max. pressure if there is a fault)	≥ 0 hPa ≤ 40 hPa	
Respiratory rate Precision Increment	6 to 45 1/min ± 0.5 1/min 1 l/min	
I:E (Ti/T): Inspiration time Increment Precision	20 % up to 67 % of the respiratory cycle 1 % ±1 %	
Trigger level	adjustable over 6 levels, separate for inspiration and expiration in the ST mode the expiration trigger can be disabled	
Rate of pressure rise	adjustable over 6 levels	
Rate of pressure drop	adjustable over 6 levels	
Precision of volume measurement	at 23 °C: ± 15 %	
Maximum flow rate to ISO 17510-1:2002 at:		
22 hPa	200 l/min	190 l/min
16.5 hPa	220 l/min	205 l/min
11 hPa	240 l/min	220 l/min
5.5 hPa	260 l/min	240 l/min
4 hPa	265 l/min	240 l/min
0 hPa	285 l/min	260 l/min
Tolerance	±15 l/min	±15 l/min

	BiLevel ST 22	BiLevel ST 22 with VENTiC/lick
Maximum flow rate to EN ISO 17510-1:2009 at: 20 hPa 16 hPa 12 hPa 8 hPa 4 hPa	210 l/min 220 l/min 225 l/min 235 l/min 245 l/min	193 l/min 205 l/min 212 l/min 219 l/min 229 l/min
Maximum flow rate with bacteria filter at: 0 hPa Tolerance	270 l/min ±15 l/min	250 l/min ±15 l/min
Warming of air as per the German HMV (Medical Technical Aids Register)	2.5 °C	depends on heating level
Precision of dynamic pressure (short-term precision) with 10 breaths/min to EN ISO 17510-1:2009 4 hPa 8 hPa 12 hPa 16 hPa 20 hPa	$\Delta p = 0.2$ hPa $\Delta p = 0.2$ hPa $\Delta p = 0.3$ hPa $\Delta p = 0.3$ hPa $\Delta p = 0.3$ hPa	$\Delta p = 0.2$ hPa $\Delta p = 0.3$ hPa $\Delta p = 0.3$ hPa $\Delta p = 0.3$ hPa $\Delta p = 0.4$ hPa
Precision of dynamic pressure (short-term precision) with 15 breaths/min to EN ISO 17510-1:2009 4 hPa 8 hPa 12 hPa 16 hPa 20 hPa	$\Delta p = 0.3$ hPa $\Delta p = 0.3$ hPa $\Delta p = 0.3$ hPa $\Delta p = 0.4$ hPa $\Delta p = 0.4$ hPa	$\Delta p = 0.3$ hPa $\Delta p = 0.3$ hPa $\Delta p = 0.4$ hPa $\Delta p = 0.4$ hPa $\Delta p = 0.4$ hPa
Precision of dynamic pressure (short-term precision) with 20 breaths/min to EN ISO 17510-1:2009 4 hPa 8 hPa 12 hPa 16 hPa 20 hPa	$\Delta p = 0.4$ hPa $\Delta p = 0.4$ hPa $\Delta p = 0.5$ hPa $\Delta p = 0.5$ hPa $\Delta p = 0.5$ hPa	$\Delta p = 0.4$ hPa $\Delta p = 0.4$ hPa $\Delta p = 0.5$ hPa $\Delta p = 0.5$ hPa $\Delta p = 0.5$ hPa

	BiLevel ST 22	BiLevel ST 22 with VENTiClick
Long-term pressure constant measured according to EN ISO 17510-1:2009	$\Delta p = 0.4 \text{ hPa}$	
Finefilter separation level to 2 μm	$\geq 99.7\%$	
Fine filter service life	1000 hours with normal room air	
Permitted humidity for operation and storage	$\leq 95 \% \text{ rF (no condensation)}$	
System resistance with an air flow of 60 l/min at the patient connector aperture.	BiLevel ST 22 with hose system WM 24130 and Silentflow WM 23600	BiLevel ST 22 with O ₂ hose system WM 23737, VENTiClick WM 24365 and bacteria filter WM 24148
	$0.20 \frac{\text{kPa} \cdot \text{s}}{\text{l}}$	$0.31 \frac{\text{kPa} \cdot \text{s}}{\text{l}}$

All values determined under ATPD conditions (ambient temperature and pressure, dry).

CE 0197 1hPa = 1 mbar

10.1 Pneumatic diagram

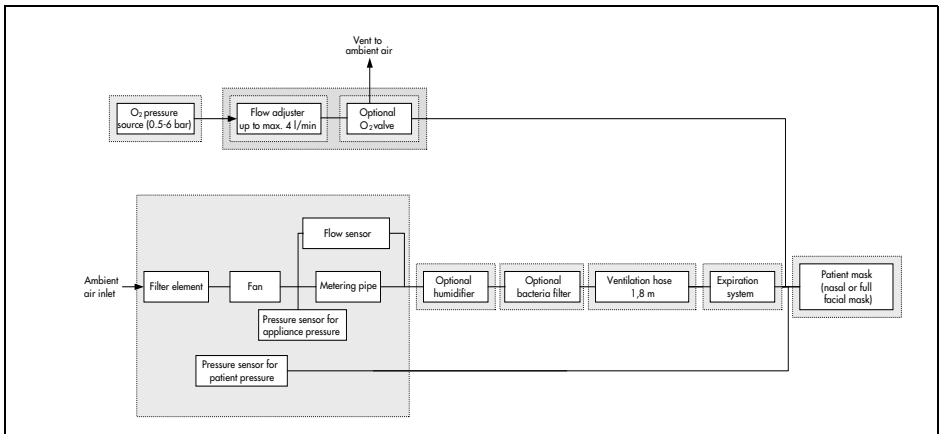

10.2 Safety distances

Recommended safety distances between portable and mobile HF telecommunications equipment (e.g. cell phones) and the BiLevel ST 22			
Nominal output of HF equipment	Safety distance dependent on transmission frequency		
	in m		
in W	150 kHz - 80 MHz	80 MHz - 800 MHz	800 MHz – 2.5 GHz
0.01	0.04	0.04	0.08
0.1	0.11	0.11	0.22
1	0.35	0.35	0.70
10	1.10	1.10	2.20
100	3.50	3.50	7.00

Further technical data can be obtained on request from Weinmann and are listed in the hospital manual and the Service and Repair Instructions.

Subject to design modifications

11. Warranty

- Weinmann offers a warranty that the product, when used in accordance with requirements, will remain free from defects for a period of two years from date of purchase. For products whose durability is clearly indicated as less than two years, the warranty expires on the expiration date indicated on the packaging or in the user's manual.
- Claims against the warranty can be made only when accompanied by the sales receipt, which must show salesperson and date of purchase.
- We offer no warranty in the case of:
 - Disregard of usage instructions
 - Operating errors
 - Improper use or improper handling
 - failure to use original spare parts
 - Third-party intervention by unauthorized persons for the purpose of device repair
 - Acts of God, e.g., lightning strikes, etc.
 - Transport damage as a result of improper packaging of returned items
 - Lack of maintenance
 - Operational and normal wear and tear, which includes, for example, the following components:
 - Filters
 - Batteries / rechargeable batteries
 - Articles for one-time usage, etc.
 - Failure to use original spare parts
- Weinmann is not liable for consequential harm caused by a defect if it is not based on intention or gross negligence. Weinmann is also not liable for minor physical injury to life or limb resulting from negligence.
- Weinmann reserves the right to decide whether to eliminate defects, to deliver a defect-free item or to reduce the purchase price by a reasonable amount.
- If Weinmann rejects a claim against the warranty, it assumes no expense for transport between customer and manufacturer.
- Implied warranty claims remain unaffected by these changes.

12. Declaration of Conformity

Weinmann Geräte für Medizin GmbH + Co. KG declares herewith that the product complies fully with the respective regulations of the Medical Device Directive 93/42/EEC.

The unabridged text of the Declaration of Conformity can be found on our website at www.weinmann.de

13. Index

Accessories	41
Alarms	34
Auto switch-on	8, 19, 20, 33
Carrying bag	23
Cleaning	24
Disinfection	24, 27
Dry the hose system.	25
Exhalation system	16, 19, 23, 24, 37
Filter	33, 37, 45
Functional check	29
Garantie	47
Inspection	10
Inspiration time	8
Malfunctions	33
Nasal mask	16, 19, 23, 24
Respiratory rate	8, 43
Safety instructions	9, 10
Side effects	12
Soft start	2, 20, 22
Technical data	42
Therapy mode	8
Traveling	23
VENTIclick	17, 22, 27, 42
VENTI-O2	17
VENTIpower	18

Weinmann Geräte für Medizin GmbH+Co.KG

Postfach 540268 • D-22502 Hamburg

Kronsaalsweg 40 • D-22525 Hamburg

T: +49-(0)40-5 47 02-0

F: +49-(0)40-5 47 02-461

E: info@weinmann.de

www.weinmann.de

Center for Production, Logistics, Service

Weinmann Geräte für Medizin GmbH+Co.KG

Siebenstücken 14
D-24558 Henstedt-Ulzburg

T: +49-(0)4193-88 91-0

F: +49-(0)4193-88 91-450