

US Instructions for Use for devices of type LM150TD

Device Firmware Version 1.13

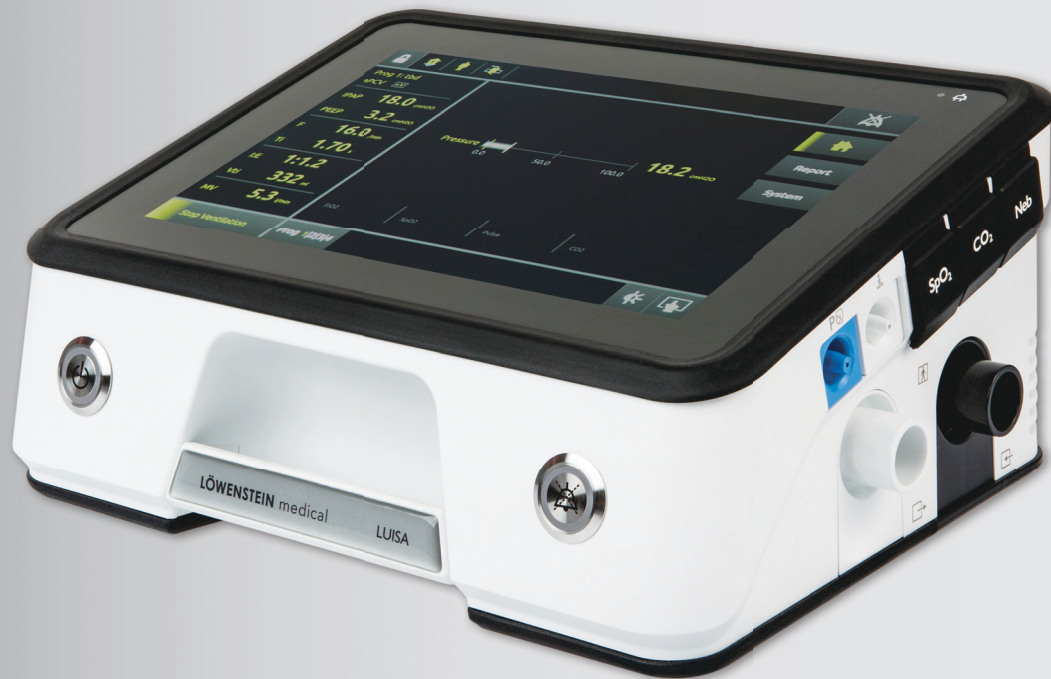

LUISA Ventilators

LÖWENSTEIN
medical

Contents

1	Introduction	3	6.3	Checking alarms	26
1.1	Indications for Use	3	6.4	Manual alarm test	28
1.2	Description of function	3	6.5	Servicing	28
1.3	User qualification	3	6.6	Disposal	28
1.4	Contraindications	4	7	Ventilation modes	29
1.5	Side effects	4	7.1	General	29
2	Safety	4	7.2	CPAP mode	29
2.1	Safety information	4	7.3	HFT mode	29
2.2	General information	5	7.4	S mode	30
2.3	Safety information in these instructions for use	6	7.5	ST mode	30
3	Product description	7	7.6	T mode	31
3.1	Overview	7	7.7	TTV-VAPS-AE mode	32
3.2	Control panel in display	8	7.8	PSV mode	33
3.3	Symbols in display	9	7.9	aPCV mode	34
3.4	Accessories (optional)	9	7.10	PCV mode	35
3.5	Operating states	10	7.11	aVCV mode	35
3.6	Batteries	10	7.12	VCV mode	36
3.7	Trolley 2.0	11	7.13	P-SIMV mode	36
3.8	USB modem	11	7.14	V-SIMV mode	37
3.9	Data management/compatibility	12	7.15	MPVp mode	38
4	Preparation and operation	13	7.16	MPVv mode	38
4.1	Setting up and connecting device	13	7.17	Overview of available ventilation modes in the circuits	39
4.2	Connecting circuit	13	8	Alarms	40
4.3	Connecting circuit for mouthpiece ventilation	14	8.1	Sequence in which alarms are displayed	40
4.4	Before first use	15	8.2	Muting alarms	40
4.5	Switching on device	15	8.3	Configuring physiological alarms	40
4.6	Starting therapy	15	8.4	Technical alarms	42
4.7	Ending therapy and switching off device	15	8.5	Nurse call and remote alarm	47
4.8	Performing circuit test	16	9	Faults	47
4.9	Calibrating FiO ₂ cell	16	10	Technical specifications	48
4.10	Measuring SpO ₂	16	11	Annex	53
5	Settings in the menu	18	11.1	Pneumatic diagram	53
5.1	Navigating in the menu	18	11.2	System resistances	54
5.2	Patient menu structure	18	11.3	Emission of electromagnetic interference	55
5.3	Expert menu	19	11.4	Electromagnetic interference immunity	55
5.4	Expert menu structure	20	11.5	Markings and symbols	55
5.5	Configuring and enabling ventilation programs	22	11.6	Scope of delivery for LMT 31390US-1110 LUISA with HFT mode	56
6	Hygiene treatment and servicing	23	11.7	Accessories	57
6.1	Hygiene treatment	23	11.8	Removable parts	57
6.2	Function check	25	11.9	Limited Warranty	57

1 Introduction

1.1 Indications for Use

The LUISA provides continuous or intermittent ventilatory support for adult patients who require mechanical ventilation. The LUISA device is intended to be used in home, institution/hospital and portable applications for both invasive and non-invasive ventilation.

Caution : The LUISA device is not intended for use as an emergency transport ventilator.

Caution: In the US, Federal law restricts this device to sale by or on the order of a physician."

The LUISA Ventilator has NOT been FDA cleared or approved. The LUISA Ventilator has been authorized by FDA under an EUA and is authorized only for the duration of the declaration that circumstances exist justifying the authorization of the emergence use of ventilators, ventilator tubing connectors, and ventilator accessories under section 564(b)(1) of the Act U.S.C. § 360bbb-3(b)(1), unless the authorization is terminated or revoked sooner.

This EUA will be effective until the declaration that circumstances exist justifying the authorization of the emergence use of ventilators, ventilator tubing connectors, and ventilator accessories during the COVID-19 pandemic is terminated under section 564(b)(2) of the Act or the EUA is revoked under section 564(g) of the Act.

1.2 Description of function

A blower takes in ambient air through a filter and pumps it through the circuit and the patient/ventilator interface to the patient. The blower is controlled to suit respiratory phases on the basis of the signals detected by the pressure and flow sensors.

The user interface is for displaying and setting the available parameters and alarms.

The device can be used with a leakage circuit, with a single circuit with valve or with a double circuit. With the leakage ventilation, the exhaled air containing CO₂ is continuously flushed out via an exhalation system. With a single circuit with valve and with a double circuit, the patient's exhalation is controlled by a valve.

In High Flow mode (HFT mode), the device pumps the set flow to an external humidifier suitable for HFT. This conditions the respiratory gas in terms of temperature and humidity. The patient connection is made using accessories suitable for HFT. HFT mode (if available) and MPV mode are not respiration support modes within the meaning of standard ISO 80601-2-72. As no permanent and/or sealed connection is made between the corresponding interfaces and the patient's airway, some specifications such as disconnection detection do not apply.

Oxygen can be supplied via the oxygen inlet.

If required, the FiO₂ concentration delivered by the device can be measured using an integrated FiO₂ sensor. External SpO₂ measurement can also be connected.

The power is supplied by an external power supply unit. The device has an integrated battery, so it can continue to be operated without interruption in the event of a power outage. In addition, a maximum of two external batteries can be connected to operate the device.

Therapy data is stored in the device and can additionally be loaded on a USB-C stick and analyzed by PC software.

1.3 User qualification

The person operating the device is referred to in these instructions for use as the user. A patient is the person receiving the therapy. The patient is also intended to be a user. As an owner/operator or user, you must be familiar with the operation of this medical device. Training and instruction in operation of the device is absolutely essential for the user and for the representative of the owner/operator. When the device is handed over to the patient, the attending physician or clinical staff must instruct the patient in the function and operation of the device.

The owner/operator is responsible for ensuring the compatibility of the device and of all the components or accessories associated with the patient before these are used.

The device is a medical device which may only be used by trained specialists as directed by a physician. Use the device only as directed by a physician or other medical staff.

For blind and partially-sighted users

An electronic version of the instructions for use is also available from the download area of the manufacturer's website.

1.4 Contraindications

If the patient has any of the following conditions, consult their health care professional before using the device in a non-invasive mode:

Inability to maintain a patent airway or adequately clear secretions; at risk for aspiration of gastric contents; diagnosed with acute sinusitis or otitis media; epistaxis, causing pulmonary aspiration of blood; hypotension.

1.5 Side effects

When using the device, the following undesired side effects may occur in the short-term or long-term use: Pressure points from the mask and the forehead cushion on the face, reddening of the facial skin, dry throat, mouth, nose, feeling of pressure in the sinuses, irritated conjunctiva in the eyes, gastrointestinal insufflation of air ("bloating"), nosebleeds; muscular atrophy in the case of long-term ventilation. These are general side effects not attributable specifically to use of devices of type LM150TD.

2 Safety

2.1 Safety information

2.1.1 Handling the device, the components, and the accessories

If the device is damaged or its function is restricted, people may be injured.

- ⇒ Only operate the device and its components if they are externally undamaged.
- ⇒ Perform a function check at regular intervals (see "6.2 Function check", page 25). Only operate, store, and transport the device within the specified ambient conditions (see "10 Technical specifications", page 48).
- ⇒ Always keep an alternative means of ventilation available in order to avoid a life-threatening situation if the device fails.
- ⇒ Circuit(s) and adaptor(s) may pose choking hazards and should be kept out of reach of children.
- ⇒ Do not use the device in an MRI environment or in a hyperbaric chamber.
- ⇒ Do not reuse disposables. Disposables may be contaminated and/or their function may be impaired.
- ⇒ Do not use or supply anesthetic gases.

- ⇒ Set acoustic alarm volume high enough for the acoustic alarm to be heard.
- ⇒ Eliminate leaks on the breathing mask or circuit. In the event of unintended leaks, the values displayed for volume and exhaled CO₂ will deviate from actual patient values.
- ⇒ Only use accessory parts from the manufacturer.
- ⇒ Do not use antistatic or electrically-conductive circuits.
- ⇒ The accuracy of the device may be impaired by the gas supplied by a pneumatic nebulizer.
- ⇒ Regularly check the breathing system filter for increased resistance and blockages. Moistening with nebulizers or humidifiers may increase the resistance of breathing system filters and thus change the therapeutic pressure delivered. In order to prevent increased resistance and blockages, replace the breathing system filter more frequently.
- ⇒ Set up external humidifiers below the device and the patient connection. Water in the device may damage the device or injure the patient.

2.1.2 Electromagnetic compatibility

The device is subject to special precautions with regard to EMC (electromagnetic compatibility). If these precautions are not followed, the device may malfunction and individuals may be injured.

- ⇒ Portable high-frequency communication equipment (e.g. radios and cell phones), including their accessories such as antenna cables and external antennas, for example, must be used at a distance of at least 30 cm from the device and its cables.
- ⇒ Do not use the device in the vicinity of active high-frequency surgical equipment.
- ⇒ Operate the device within the EMC environment specified for this device (see "11.4 Electromagnetic interference immunity", page 55) in order to prevent key performance characteristics being affected - for example, ventilation parameters being affected by electromagnetic interference.
- ⇒ Do not operate the device if the housing, cables or other equipment for electromagnetic shielding are damaged.
- ⇒ The use of third-party accessories, third-party inverters and third-party cables may lead to increased electromagnetic interference or reduced electromagnetic interference immunity of the device and to faulty operation. Only use original connecting cables from the manufacturer.
- ⇒ Do not operate the device in the immediate vicinity of other devices, otherwise there may be malfunctions. If it is necessary to operate the device in the immediate vicinity of other devices, keep all the devices under observation to ensure that they are all operating properly.

2.1.3 Energy supply

Operating the device outside the specified energy supply may injure the user, damage the device or impair the performance of the device, and injure the patient.

- ⇒ Operate the power supply unit only at voltages from 100 V to 240 V.
- ⇒ The device is intended for operation at voltages from 12 V, 24 V DC and 48 V DC.
- ⇒ Keep access to the power supply connector and the power supply free at all times.
- ⇒ When using a battery-operated wheelchair: Connect the device to the wheelchair battery only if a connection of that kind is expressly provided in the instructions for use for the wheelchair.
- ⇒ When operating using the cigarette lighter socket in a car: Disable the car's auto start/stop feature. Start the car first, then connect the device.

2.1.4 Handling oxygen

Supplying oxygen without a special safety device can lead to fire and injure people.

- ⇒ Follow the instructions for use for the oxygen supply system.
- ⇒ Set up oxygen sources at a distance of over 1 m from the device.
- ⇒ The oxygen rate supplied in l/min must not exceed the oxygen flow prescribed by the physician.
- ⇒ The oxygen rate supplied in l/min may not exceed the set HFT flow rate.
- ⇒ At the end of therapy, shut off the oxygen supply and allow the device to run on briefly to flush residual oxygen out of the device.

2.1.5 Transport

Operating the device in any kind of carrying bag may impair device performance and injure the patient. Water and dirt in the device may damage the device.

- ⇒ Only operate the device in the associated LUISA mobility bag.
- ⇒ Transport or store the device in the associated LUISA protective bag.

2.1.6 SpO₂ measurement

If SpO₂ measurement is performed incorrectly, it may injure the patient and affect the accuracy of the measurement.



- ⇒ Only use the SpO₂ sensors and cables listed in these instructions for use (see "11.7 Accessories", page 57).
- ⇒ For photodynamic treatments, note the peak values of wavelengths, optical output power, and the use (see instructions for use of the 8000SX sensor).

- ⇒ Check and, if possible, eliminate environmental influences that may impair the function or accuracy of the SpO₂ sensors: excessive peripheral lighting, excessive movement, interference due to electrosurgical instruments, moisture in the sensor, incorrectly attached sensor, carboxyhemoglobin, restriction of the blood flow (due to arterial catheters, blood pressure cuffs, infusion lines, etc.), incorrect sensor type, poor pulse quality, venous pulse, anemia or low hemoglobin concentrations, cardiovascular dyes, dysfunctional hemoglobin, artificial fingernails or nail polish, residues (e.g. dried blood, dirt, oil, grease) in the light path.

2.2 General information

- In order to react to an alarm and, if necessary, to use emergency ventilation, you must subject both patient and device to regular monitoring.
- The use of third-party articles may lead to incompatibility with the product. In such cases, please be aware that any claim under warranty and liability will be void if original spare parts are not used.
- Connection by cable to a patient monitor is not a substitute for a remote alarm system. Alarm data are transmitted only for documentation purposes.
- Have measures such as repairs, servicing, and maintenance work, as well as modifications to the product, carried out exclusively by the manufacturer or by specialists expressly so authorized by the manufacturer.
- Connect only the licensed products and modules in accordance with these instructions for use. The products must meet the product standard applicable to them. Non-medical equipment should be positioned out of the patient's vicinity.
- Follow the section on hygiene treatment (see "6 Hygiene treatment and servicing", page 23) to avoid infection or bacterial contamination.
- In the event of a power outage, all settings including alarm settings are retained.

2.3 Safety information in these instructions for use

 WARNING	Indicates an unusually significant hazardous situation. If you ignore this instruction, severe irreversible or fatal injuries may result.
 CAUTION	Indicates a hazardous situation. If you ignore this instruction, mild or moderate injuries may result.
NOTICE	Indicates a harmful situation. If you ignore this instruction, material damage may result.
	Indicates useful information within procedures.

3 Product description

3.1 Overview

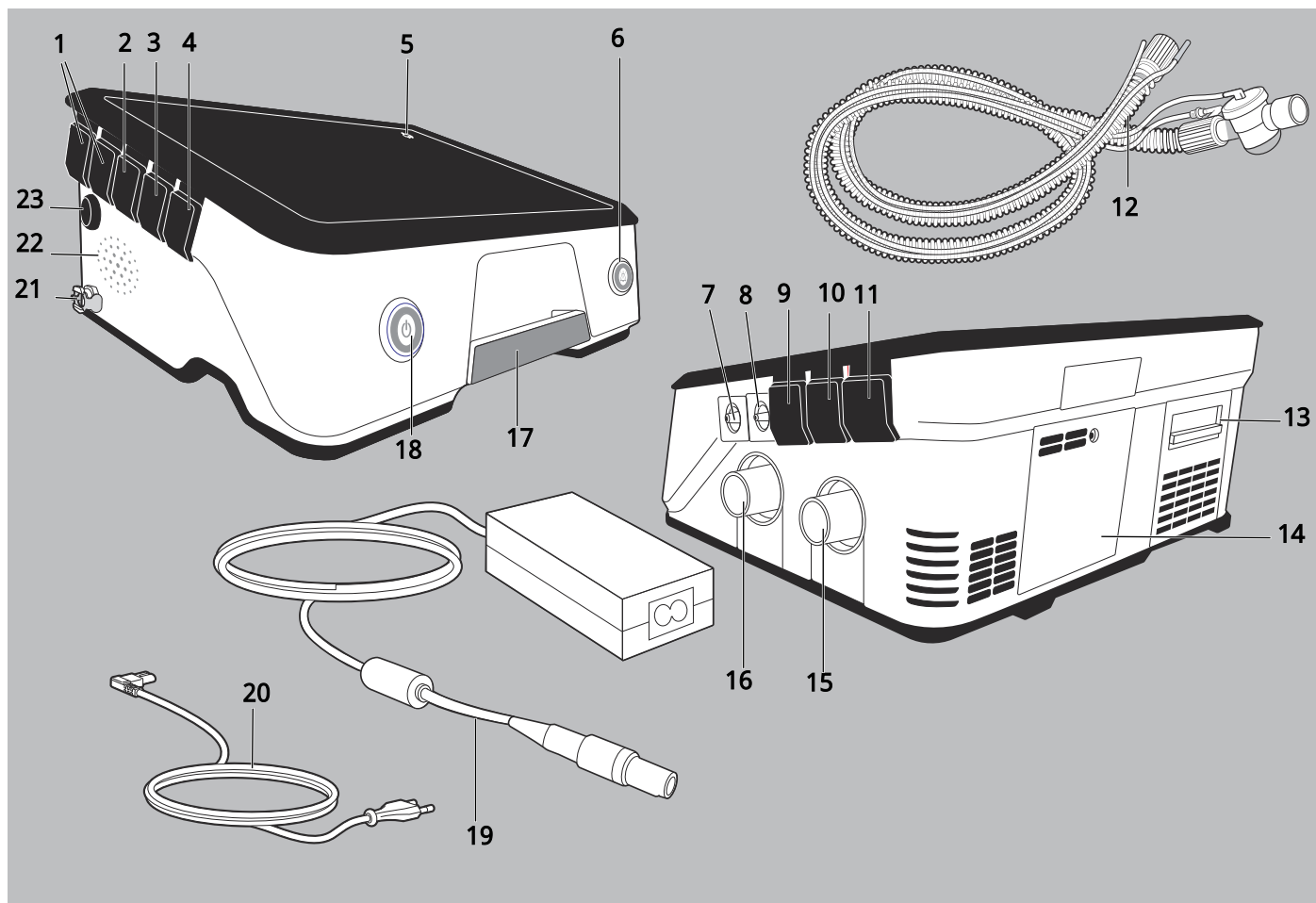





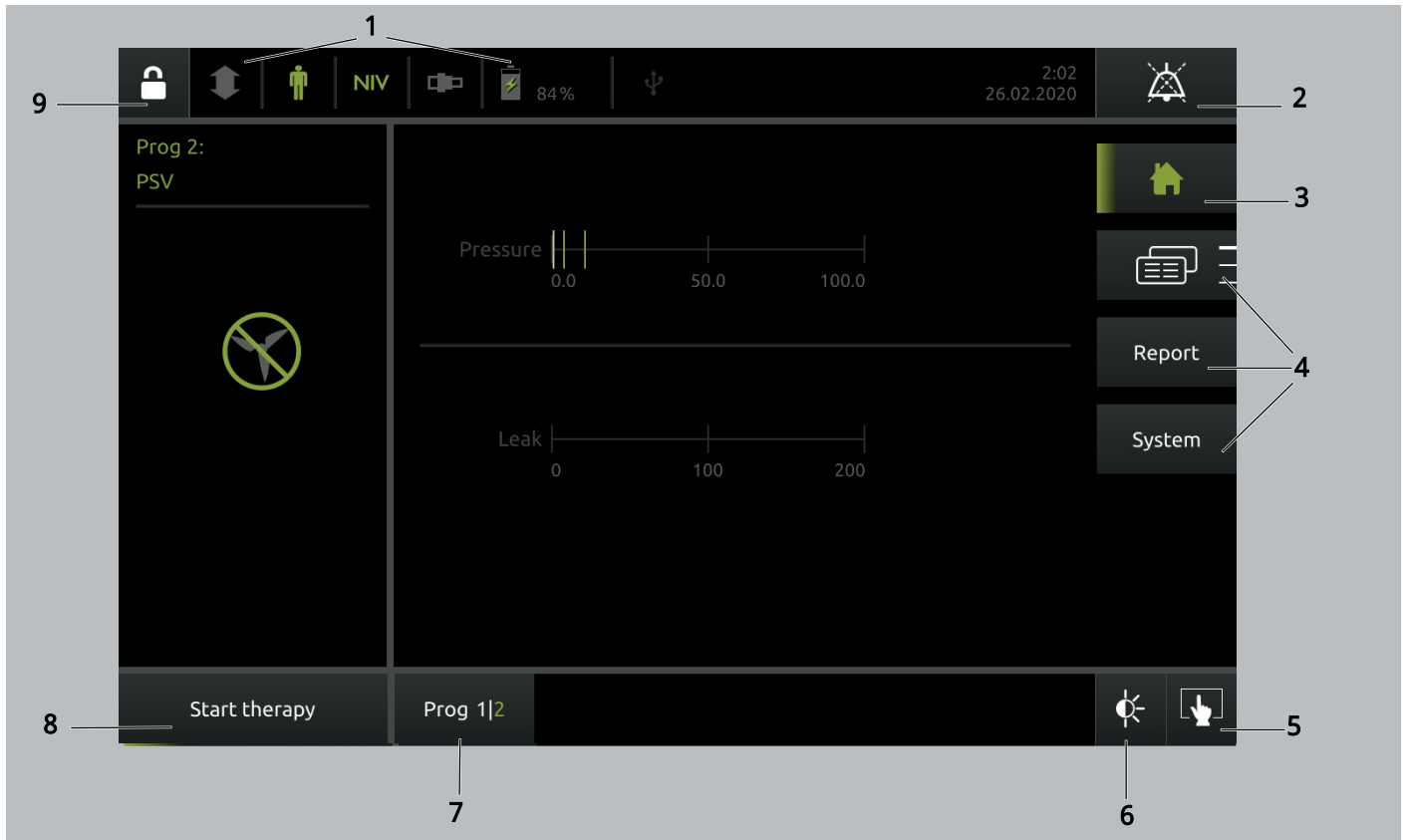











- | | | | |
|----|-----------------------------------------|----|------------------------------------------------------------|
| 1 | External battery connection | 13 | Filter compartment with coarse dust filter and fine filter |
| 2 | Connection for monitor | 14 | Compartment for internal battery |
| 3 | USB-C connection | 15 | Exhalation circuit connection |
| 4 | Nurse call system connection | 16 | Device outlet port |
| 5 | Power supply indicator | 17 | Handle |
| 6 | Alarm acknowledgement key | 18 | On/off key |
| 7 | Pressure measuring tube connection | 19 | Power supply unit with power supply unit cable |
| 8 | Valve control tube connection | 20 | Power cable |
| 9 | SpO ₂ connection | 21 | O ₂ supply connection |
| 10 | CO ₂ connection (not in use) | 22 | Loudspeaker |
| 11 | Nebulizer connection (not in use) | 23 | Power supply unit connection |
| 12 | Circuit | | |











3.2 Control panel in display



- 1 Status line - symbols indicate current device status (e.g. accessories connected, battery capacity).
- 2 Alarm acknowledgement key -
Press briefly: Acknowledges alarm. If the alarm persists, the alarm is muted for 2 minutes.
Press and hold: Mutes all acoustic alarms for 2 minutes.
Press briefly again: Suspends alarm muting.
- 3 Home key - switches the view back to the start screen.
- 4 Menu keys - provide access to the individual menus.
- 5 Display lock key - locks or unlocks the display, so that no settings can be changed as a result of incorrect contact. Display will unlock automatically in presence of alarm.
- 6 Dimmer key - switches to night mode and the display goes dark.
Touch the display to reactivate it.
Keep key depressed - opens the **Display** menu.
Display will reactivate automatically in presence of alarm.
- 7 Program key - provides access to the ventilation programs.
- 8 Ventilation key - starts or stops ventilation.
- 9 Access key - locks or unlocks the Expert menu.

3.3 Symbols in display

SYMBOL	DESCRIPTION
	Device in Patient menu. Expert menu locked.
	Expert menu enabled.
	Indicates respiratory status: <ul style="list-style-type: none"> • Arrow pointing upward: Inspiration • Arrow pointing downward: Exhalation • S: Spontaneous breath • T: Mandatory breath
	Device set for adults.
NIV	non-invasive ventilation/patient interface
IV	invasive ventilation/patient interface
	Leakage circuit set.
	Single circuit with valve set.
	Double circuit set.
	Battery charging. If the gray area reaches the top, the battery is fully charged.
	Battery capacity high, battery discharging.
	Battery capacity medium, battery discharging.
	Battery capacity low, battery discharging.
	Battery capacity low.
	Battery fault
	Filter change (only if function is activated).
	Service reminder function (only if function is activated).
SpO₂	SpO ₂ sensor: <ul style="list-style-type: none"> Gray: Not connected Green: Connected and high signal quality Yellow: Connected and moderate signal quality Red: Connected and poor signal quality
FiO₂	FiO ₂ cell <ul style="list-style-type: none"> Green: Activated and full Gray: Activated and empty Green and flashing: Calibration process in progress
	Flight mode

SYMBOL	DESCRIPTION
	Green: Data are transmitted. Gray: USB flash drive connected, no data are transmitted
	Gray: USB modem connected Gray and flashing: USB modem is connecting
	USB modem has set up a connection. The green lines show the signal quality.
	Data transmission
	USB modem faultily
	Low-priority alarm triggered.
	Medium-priority alarm triggered.
	High-priority alarm triggered.
	All physiological alarms have been deactivated.
	Acoustic signal for alarm paused.

3.4 Accessories (optional)

PART	DESCRIPTION
VENTIremote alarm	For remote transmission and display of the alarm signals output by the device
SpO ₂ sensor	Determines SpO ₂ and pulse frequency data
Breathing system filter	Prevents the transmission of particles and microorganisms to the breathing system
FiO ₂ cell	Performs permanent FiO ₂ measurement
Circuit	Supplies the patient with respiratory air
Exhalation valve	Routes exhaled air into the environment
External battery	Serves as an additional external energy supply for the device
Protective bag for LUISA	Serves to transport and store the device with protection

3.5 Operating states



Follow the instructions for use for the accessories. Here you will find further information about operation and combining accessories with the device.

- **On:** Therapy is in progress. It is possible to make changes to device and therapy settings.
- **Standby:** The blower is off and therapy is not in progress. However, the device is ready for operation immediately. It is possible to make changes to device and therapy settings.
- **Off:** The device is switched off. No setting changes are possible.

3.6 Batteries

3.6.1 Internal battery

- The device is fitted with an internal battery. If the device is no longer connected to the power supply or there is a power outage, the battery automatically starts supplying the device without interruption. This discharges the battery. The battery is charged automatically again as soon as the device is connected to the power supply. In operation via a 12 V or 24 V supply, the battery is charged only when the device is in the **Standby** or **Off** state.
- The internal battery is replaced by the manufacturer or by a specialist dealer so authorized by the manufacturer.
- Battery life depends on therapy settings and ambient temperature (see “10 Technical specifications”, page 48).
- When the **Battery capacity low** alarm appears, only 15 minutes’ life remains. When the **Battery capacity critical** alarm appears, the device will switch off in a few minutes’ time (less than 5 minutes’ life remaining). Have an alternative ventilation option available and connect the device to the power supply.
- If device and battery have been stored outside the specified operating temperatures, the device can only be started up once it has warmed up or cooled down to the permitted operating temperature.

3.6.2 External batteries

- External batteries can be connected to the device as an additional energy supply. If the device is

connected to the power supply, the batteries are charged; first the internal battery, then the external batteries. In operation via a 12 V or 24 V supply, the batteries are charged only when the device is in the **Standby** or **Off** state.

- If no power supply is connected, a battery supplies the device. The external batteries connected are discharged first, followed by the internal battery.

3.6.3 Display of remaining device life

Remaining device life in the case of battery and power supply operation is displayed in the status line and in the **Views** menu (see “5.2.1 Views menu in the Patient menu”, page 18).

	DEVICE ON STANDBY	DEVICE IN THE ON STATE
POWER SUPPLY	Value in %	Value in %
BATTERY SUPPLY	Value in %	Remaining battery life in h and min.

Remaining life is a prediction and always relates to the current mean consumption of the device.

Following the start of ventilation, no more than 3 minutes will elapse before remaining life is displayed.

3.7 Trolley 2.0

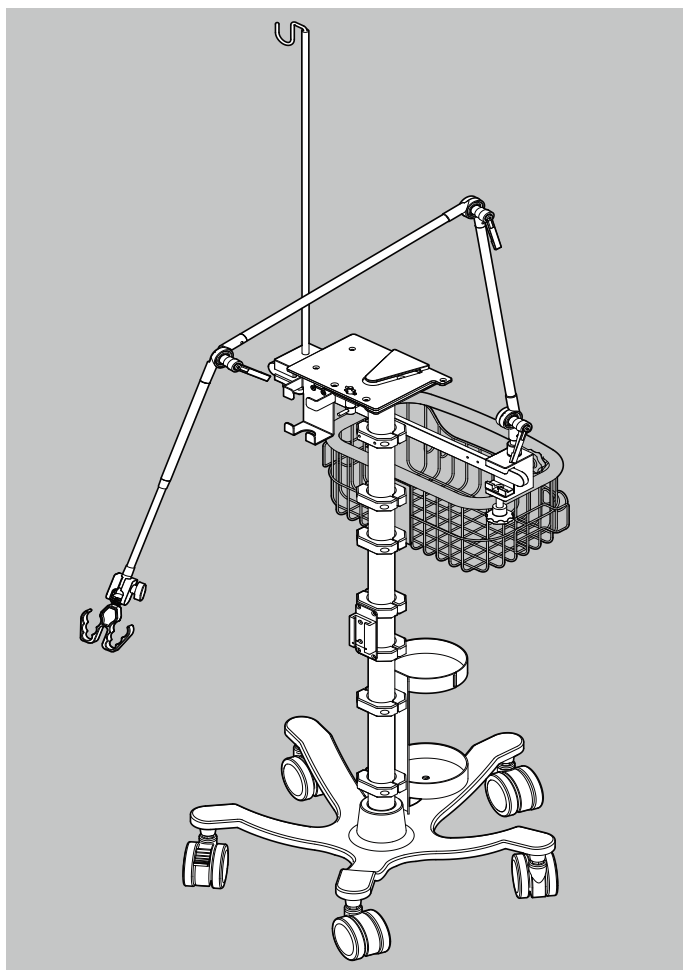

You can use the oxygen cylinder clamp with oxygen cylinders up to 120 mm in diameter (this corresponds to a cylinder size of approx. 4 l to 6 l per cylinder). Note total cylinder height (cylinder including valve and accessories).

NOTICE

Material damage if incorrectly configured!

If trolley 2.0 is not used properly, it may tip over or be damaged.

- ⇒ Use the circuit holder only for the circuit.
- ⇒ Use the water bag holder only for the refill unit of the active humidification system.
- ⇒ Use trolley 2.0 only on a maximum incline of 10°.
- ⇒ Ensure that the total weight of trolley 2.0 when fully equipped is < 25 kg.

- i** Before moving the trolley: Put the circuit holder in the folded-away position.

3.8 USB modem

The USB modem is intended only to upload data from the ventilator to the prismaCLOUD software.

- i** To connect the USB modem to the device, follow the instruction leaflet included with the USB modem. The USB modem does not allow any changes to be made to the device or the device settings.

3.8.1 Connection to prismaCLOUD

If the serial number of the device is known in prismaCLOUD, the USB modem connects to prismaCLOUD automatically.

If the serial number of the device is not known, a PIC (Personal Identification Code) can be downloaded onto a USB-C flash drive from prismaCLOUD (via a personal access facility). When the USB-C flash drive is connected to the device, the PIC is transmitted and the serial number is detected. The serial number is now known when the modem is connected and the USB modem can connect to prismaCLOUD automatically.

The connection status and signal strength of the modem connection are shown in the display (see “3.3 Symbols in display”, page 9). If the USB modem is connected to prismaCLOUD, there are only limited options for setting date and time on the device.

3.8.2 Automatic data transmission by modem

Once the modem has been configured and connected, data is transmitted in either the On or Standby operating states. Therapy data are transmitted to prismaCLOUD twice a day. The time of transmission is specified in prismaCLOUD.

If the following restrictions apply, data is transmitted at a later point in time:

- Flight mode activated
- Low battery capacity
- Inadequate signal strength

To check when data was last transmitted, call up the **System > Device settings > Connectivity > Modem** menu.

3.9 Data management/ compatibility



Anyone who integrates medical devices or medical software products in an IT network or installs them on a PC or integrates devices or software products in a medical IT network or installs them on a PC is responsible for complying with IEC 80001-1.

According to IEC 80001-1, the owner/operator is responsible for the risk management of any interactions in medical IT networks. Please note that the manufacturer does not accept any warranty or liability for interactions between system components in an IT network.

3.9.1 Saving and transmitting therapy data

Therapy data for the previous 30 therapy days (24 hours/day) are saved in the device. Pressure, flow and volume are saved at 20 Hz, all other recorded values at 1 Hz.

Statistical data for the previous 12 months are saved in the device.

Saving therapy data on USB flash drive

A file in edf format is created for every day saved. If you plug USB flash drive LMT 31414 into the device, the therapy data saved in the device will be transmitted to the flash drive in the form of edf files.

The therapy data saved on the USB flash drive can be read into and displayed in the prismaTS software and prismaCLOUD.

Transmit therapy data to prismaCLOUD manually via USB modem

As an alternative to automatic transmission (see 3.8.2, p. 11) you can transmit therapy data manually via the connected USB modem.

Select the **System > Device settings > Connectivity > Modem > Data transfer** menu.

Updating the firmware

In order to perform a firmware update, plug a USB flash drive with an update file (one version higher than the current version) into the device and confirm that the update should go ahead.

The firmware update may also include a firmware update for the internal or external batteries.

The device configuration is retained following the update.



4 Preparation and operation

4.1 Setting up and connecting device

CAUTION

Risk of injury from inadequate therapy if air inlet and air outlet are blocked!

A blocked air inlet and/or air outlet can cause the device to overheat, impair therapy and damage the device.

- ⇒ Keep the air inlet clear.
- ⇒ Keep the filter compartment clear ( symbol).
- ⇒ Keep the outlet for the patient's exhaled air free ( symbol).
- ⇒ Keep the intake opening for the cooling system free ( symbol).

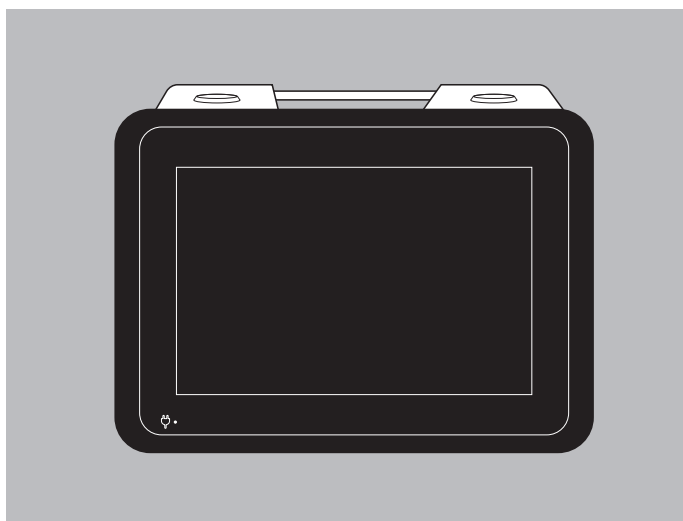

1. If required: Tilt the device to a horizontal or vertical position.
The display adapts to the orientation automatically.

NOTICE

Material damage from overheating!

Excessive temperatures may lead to the device overheating and damage the device.

- ⇒ Do not cover device and power supply unit with textiles (e.g. bedclothes).
- ⇒ Do not operate device in the vicinity of a radiator.
- ⇒ Do not expose device to direct sunlight.
- ⇒ Only operate the device in the associated mobility bag for mobile use.

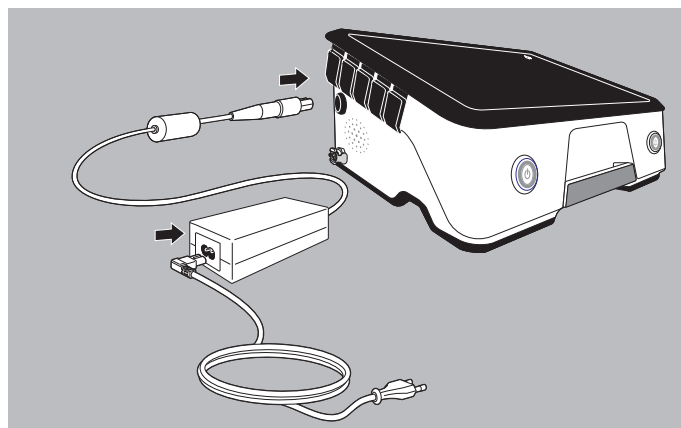

2. Connect the power cable to the power supply unit and the socket.
3. Connect the power supply unit cable to the device.

i Alternatively, you can connect a direct voltage electricity supply (12 VDC or 24 VDC) as per ISO 80601-2-72.

4.2 Connecting circuit

WARNING

Risk of asphyxia if invasive or non-invasive patient/ventilator interfaces without an exhalation system are used!

If invasive or non-invasive patient/ventilator interfaces without an integrated exhalation system are used, CO₂ concentration may rise to critical values and put the patient at risk.

- ⇒ Use invasive or non-invasive patient/ventilator interfaces with an external exhalation system if there is no integrated exhalation system.
- ⇒ Follow the instructions for use for the exhalation system.

WARNING

Risk of injury from disconnection!

When using an invasive patient interface it may lead to unintended disconnection which may not be detected.

- ⇒ Ensure correct and tight fit of the circuit and ventilation/patient interface, especially with invasive ventilation interface.
- ⇒ Check alarm settings and adjust to the therapy if required.

CAUTION**Risk of injury from incorrectly routed circuit and cables!**

Incorrectly routed circuit or cables may injure the patient.

- ⇒ Do not route circuit and cables along the neck.
- ⇒ Do not crush circuit and cables.

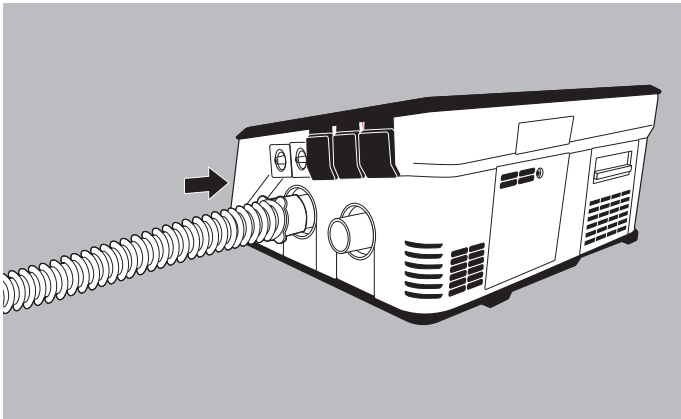
4.2.1 Connecting leakage circuit

1. Push the circuit onto the device outlet port.
2. Connect the invasive or non-invasive patient/ventilator interface to the leakage circuit (see instructions for use for the patient/ventilator interface).

4.2.2 Connecting single circuit with valve**WARNING****Risk of injury from limited disconnection detection!**

If a single circuit with valve is used without a proximal pressure measurement line and with additional accessories (tube extension, HME/F etc.), disconnection will be detected to only a limited extent.

- ⇒ Check alarm settings and adjust to the therapy if required.

WARNING**Risk of injury if patient valve is covered!**

If the patient valve is covered, exhaled air can no longer be routed away and the patient will be put at risk.

- ⇒ Always keep the patient valve free.

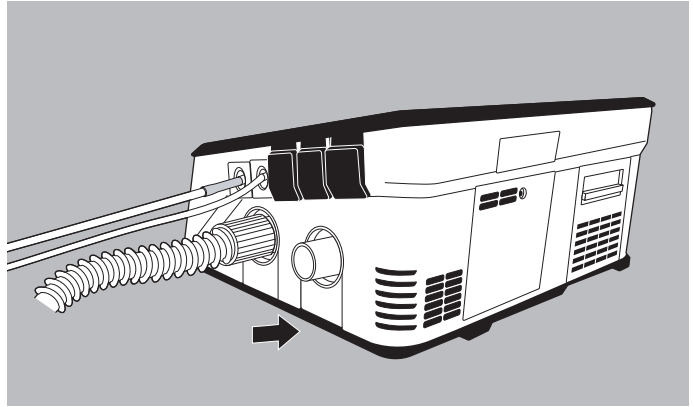

1. Push the free end of the circuit onto the device outlet port.
2. Connect the pressure measuring tube to connection P.
3. Connect the valve control tube to connection V.

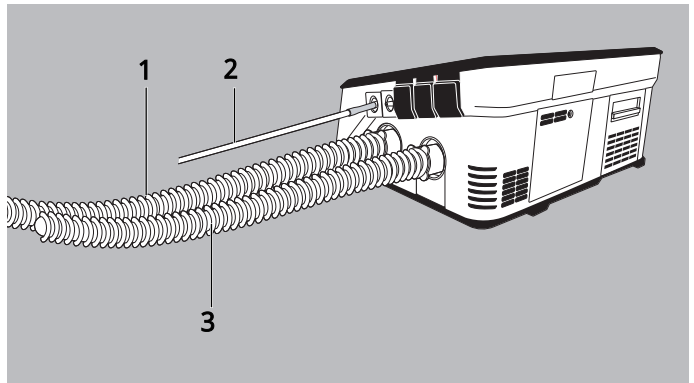
4.2.3 Connecting double circuit

1. Push the free end of the circuit 1 onto the device outlet port.
2. Push circuit 3 onto the device inlet for exhaled air.
3. Connect the pressure measuring tube 2 to connection P.
4. Connect the patient/ventilator interface (e.g. mask) to the Y-piece of the circuit.

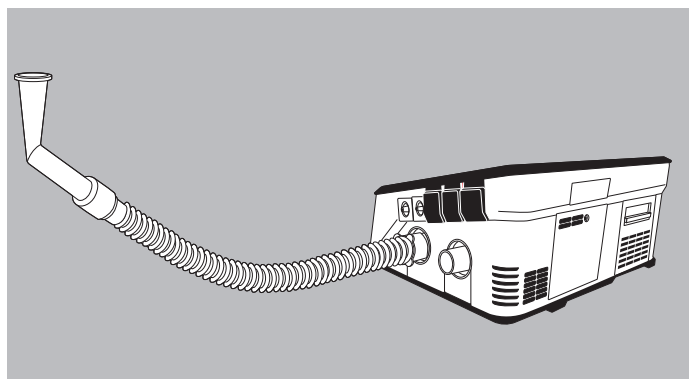
4.3 Connecting circuit for mouthpiece ventilation

1. Push the free end of the circuit onto the device outlet port.
2. Connect mouthpiece to the circuit (see instructions for use for the patient/ventilator interface).

i As an alternative to the leakage circuit, it is also possible to use a single circuit with valve or double circuit for mouthpiece ventilation.

4.3.1 Connecting the circuit for HFT mode

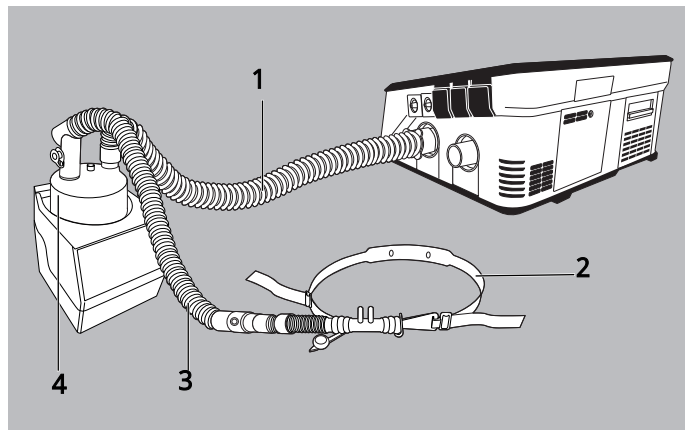

1. Push the free end of short circuit 1 onto the device outlet port.
2. Push the other end of short circuit 1 onto the connection for humidifier chamber 4 marked **In**.
3. Push long circuit 3 onto the connection for humidifier chamber 4 marked **Out**.
4. Connect High Flow interface 2 to long circuit 3.
5. If necessary, connect the circuit heater and temperature probe to long circuit 3 (see instructions for use for external humidifier).

i As an alternative to the leakage circuit, it is also possible to use the single circuit with valve or the double circuit in HFT mode.

4.4 Before first use

The device must be configured before being used for the first time. If your specialist dealer has not yet done so, you must set language and time on the device.

The device is supplied with a charged internal battery. To charge the internal battery fully, leave the device connected to the power supply for at least 1 hour.

4.5 Switching on device

Requirement

- Device is set up and connected (see “4.1 Setting up and connecting device”, page 13).

- Patient/ventilator interface is connected (see instructions for use for patient/ventilator interface).

1. Briefly press On/off key .

Alternatively

In battery mode: Press and hold On/off key  for approx. 1 second.

The device automatically performs a few function tests. The alarm system is tested automatically. If the device is fully functional (after approx. 20 seconds), the start screen is displayed and the device switches to standby.

4.6 Starting therapy

Requirement

- Device is set up and connected (see “4.1 Setting up and connecting device”, page 13).
- Patient/ventilator interface is connected (see instructions for use for patient/ventilator interface).
- Device is switched on (see “4.5 Switching on device”, page 15).

▲ WARNING

Risk of injury from a device with restricted function.

If the device is damaged or its function is restricted, the patient may be injured.

- ⇒ Only operate the device and its components if they are externally undamaged.
- ⇒ Perform a function check at regular intervals.
- ⇒ Do not use the device if the automatic function check issues error messages.
- ⇒ Always keep an alternative means of ventilation available.

1. If required: Turn device to a horizontal or vertical position.

2. Briefly press On/off key .

Alternatively

Press the **Start therapy** ventilation key in the display.

4.7 Ending therapy and switching off device

1. Press On/off key  long enough for the green progress bar to run through completely. Confirm the end of therapy.

Alternatively

Press the **End therapy** ventilation key in the display long enough for the green progress bar to run through completely. Confirm the end of therapy. The device switches to standby.

2. To switch off the device completely, press On/off key  until the message **Shutting down device** is no longer displayed and the display goes out.

4.8 Performing circuit test

Perform a circuit test at every function check, on change of patient and as required. This checks for resistance, compliance and leaks.

Requirement:

*The device is in the **Standby** state.*

*Ventilator/patient interface and type of circuit used are selected in the **Ventilation** menu.*

1. Follow the instructions in the display and connect or remove circuit, ventilator interface and accessories to or from the device. If present: Disconnect the connection to the patient.
2. Select the **System > Circuit test** menu.
3. In the **Circuit test overview** area, press the **Start** key.
4. Press the **Ok** key to start the circuit test.
5. Follow the instructions on the display and connect or remove circuit, ventilator interface and accessories to or from the device.
6. In order to continue with the circuit test, press the **Continue** key.
7. If the circuit test is successful, press the **Finish** key. If the circuit test is not successful, follow the instructions in the display and eliminate the faults.

4.9 Calibrating FiO₂ cell

You can use the optional FiO₂ cell to perform continuous FiO₂ measurement. You must activate the FiO₂ cell before use and calibrate it every 6 weeks. Calibration can take place during ventilation. You cannot perform FiO₂ measurement during the calibration process (duration approx. 5 minutes).

 Calibration is performed in the **System > FiO₂ cell > Calibrate** menu.

1. Disconnect the O₂ supply.
2. Press the **Ok** key to start calibration.
3. If calibration is successful, press the **Finish** key. If calibration is not successful, follow the instructions in the display and eliminate the faults.
4. Reconnect the O₂ supply.

The FiO₂ cell is fitted and replaced by a professional care giver such as respiratory therapist or authorized specialist dealer. If the FiO₂ cell is almost empty, a message will appear and the FiO₂ cell must be replaced (see “6.5.1 Replacing FiO₂ cell”, page 28).

 To stop the alarm occurring, you can deactivate the cell in the **System > FiO₂ cell** menu.

4.10 Measuring SpO₂

You can measure oxygen saturation (SPO₂) and pulse rate using the SpO₂ sensor. The values are stored in the ventilator, can be read out by the healthcare professional by exporting the therapy data, and displayed using the prismaTS software.

You can set alarms to monitor SpO₂ values (see “8 Alarms”, page 40).

Following a power outage lasting more than 30 seconds, all settings and data are retained. The latest settings of the SpO₂ sensor are restored automatically.

CAUTION

Risk of injury from SpO₂ sensor pressure points!

- ⇒ Avoid excessive pressure caused by the SpO₂ sensor.
- ⇒ Check that the SpO₂ sensor is attached properly at least every 6 to 8 hours to ensure that the sensor is positioned correctly and the skin is undamaged. Sensitivity to sensors may vary depending on the patient's state of health or skin condition.

Requirement: The SpO₂ sensor has been calibrated to display functional oxygen saturation.

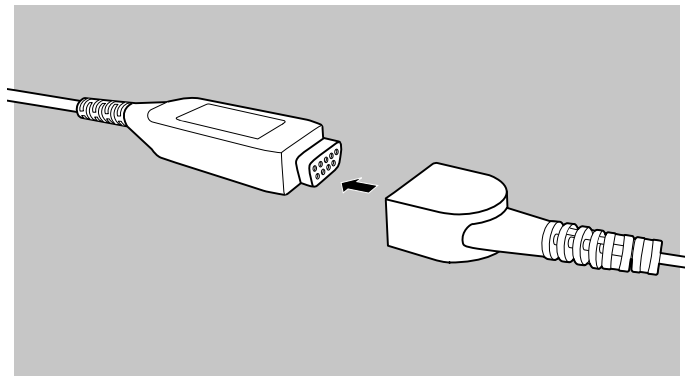

1. Connect the SpO₂/Xpod® cable to the SpO₂ sensor.

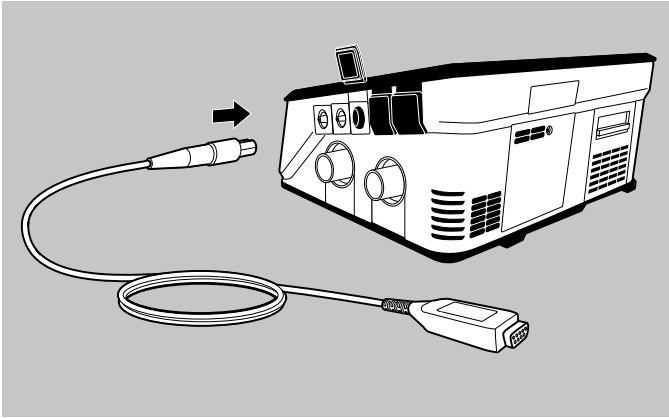



2. Connect the SpO₂/Xpod® cable to the device.
3. Place the SpO₂ sensor on the patient (e.g. on the finger).
The measured values (SpO₂ and pulse) are shown on the home display.

5 Settings in the menu

5.1 Navigating in the menu

ACTION	FUNCTION
Press function key	Function keys have a gray background and the function is displayed on the key in text or as a symbol (e.g. System , Start therapy , or ). Symbols on a black background are not function keys, but serve to provide information about device status (see "3.3 Symbols in display", page 9).
Scroll in list	Navigate up or down

ACTION	FUNCTION
Press "Value"	Opens range of values for setting ventilation parameters
Move range of values up or down	Decrease or increase value
	Confirm value
	Discard selection
	Switches the view back to the start screen

5.2 Patient menu structure

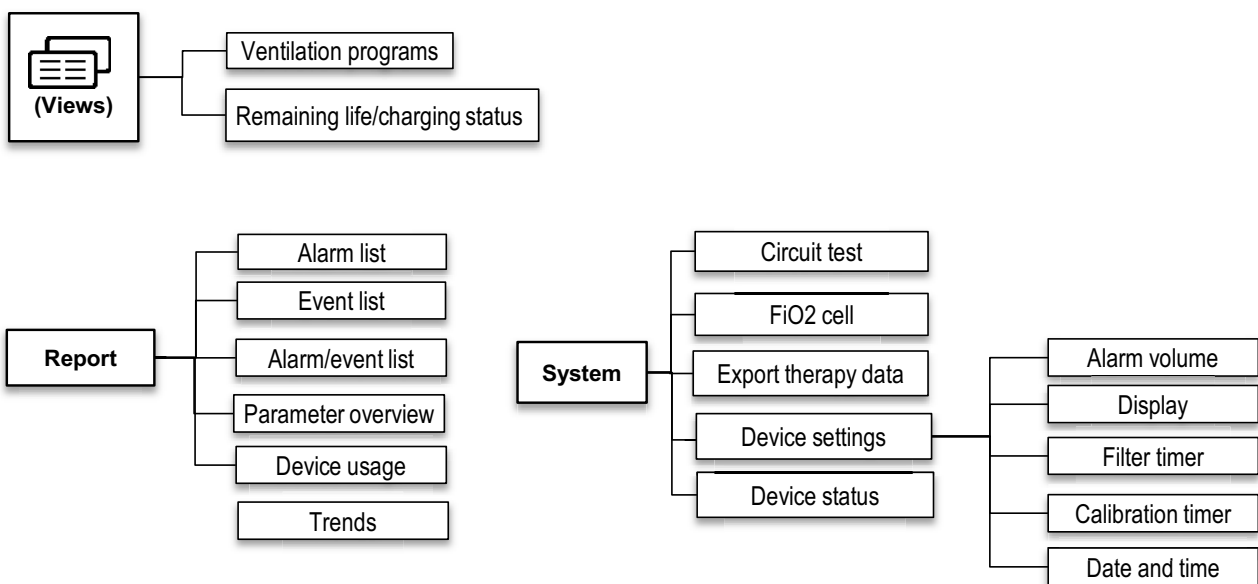

5.2.1 Views menu in the Patient menu

The **Views** menu shows 2 views.



Parameters and set values for the ventilation programs

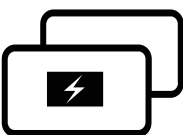

In the **On** state: Remaining device life if being supplied by battery
 In the **Standby** state: Charging state of the internal battery in percent assuming a power supply

To switch to the next view in each case, tap the Views key again. The horizontal lines on the Views key are the number of available views.

5.2.2 Report menu in the Patient menu (usage data)

Information about the parameters in this menu can be found in the table below.

PARAMETER	DESCRIPTION
Alarm list	Lists the alarms which have occurred. The log is retained when the alarm system or the device is switched off. The start and end of ventilation is recorded. The log is retained even if the device is disconnected from the power supply and the batteries are removed. The log can store 1,000 alarms. Once this capacity limit has been reached, the oldest alarm is deleted and the new alarm is saved.
Event list	Lists the events that have occurred.
Alarm/event list	Lists the alarms and events which have occurred in chronological order.
Parameter overview	Lists all parameters and set values for the up to 4 ventilation programs which can be configured.
Device usage	Obtain information here about the patient's therapy (duration, days used, program proportions) and about device usage (operating time, internal battery life remaining or charging state of internal battery in percent).
Trends	Access to the graphical displays of the therapy parameters

5.2.3 System menu in the Patient menu



Circuit test	Perform a circuit test here on change of patient and as required. This checks for resistance, compliance and leaks (see "4.8 Performing circuit test", page 16).
FiO ₂ cell	Activate or deactivate the FiO ₂ cell and calibrate the FiO ₂ cell here.
Export therapy data	You can export the set device settings here. A USB flash drive must be connected for exporting.
Device settings	You can configure the device here (see "5.2.4 Device settings submenu", page 19).
Device status	Obtain information here about the device (name, type, serial number of device and components, firmware version) and about the internal battery.

5.2.4 Device settings submenu



PARAMETER	DESCRIPTION
Alarm volume	The patient can set the alarm level here. 1= very quiet, 2= quiet, 3= loud, 4= very loud You can test the alarms here.
Display	You can set brightness, orientation, and the screen background here.
Filter timer	You can activate and reset the filter change reminder function here.
Calibration timer	You can activate and reset the reminder function for calibrating FiO ₂ cell here.
Date and time	You can set the current date and time here.

5.3 Expert menu

5.3.1 Call up and exit expert menu

1. Press and hold access symbol  until the progress bar has run its full length. The  symbol appears. The expert menu has been called up.

Alternatively

2. Press and hold access symbol  until the progress bar has run its full length. The  symbol appears. The patient menu has been called up.

5.4 Expert menu structure

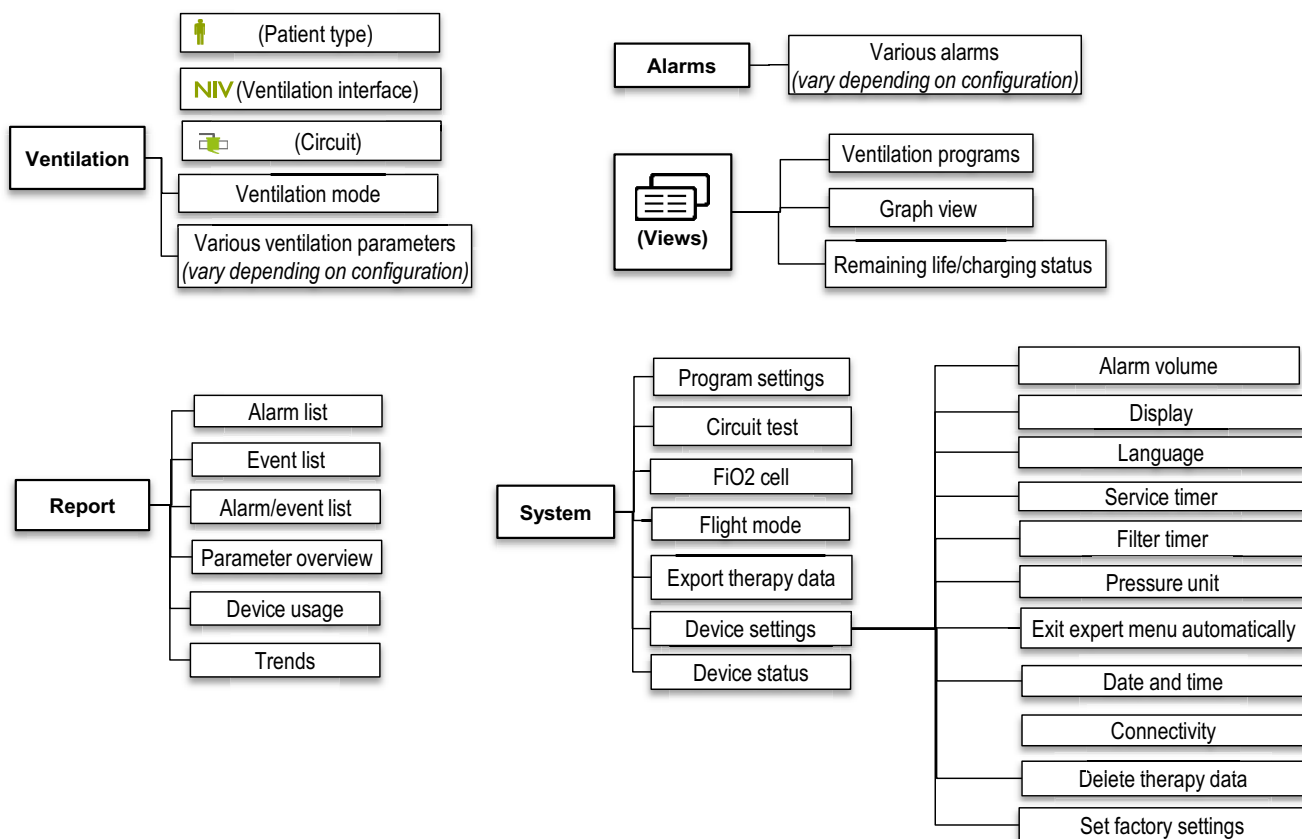

5.4.1 Ventilation menu

The **Ventilation** menu shows the settings of the current ventilation parameters. The parameters which can be displayed and modified vary depending on the ventilation mode set.

In the **Ventilation** menu, you can



- select a ventilation mode
- set ventilation parameters
- set a circuit
- select the patient type: adult
- select ventilation/patient interface
If the non-invasive (NIV) patient interface is selected, all alarm settings can be changed or switched off.
If the invasive (IV) patient interface is selected, the ventilator activates volume and leakage alarms to suit the circuit selected. It is not possible to deactivate these alarms.

5.4.2 Alarms menu

The **Alarms** menu shows the alarms and alarm limits set for the selected ventilation mode. You can adjust the values.

5.4.3 Views menu

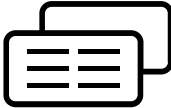
The **Views** menu shows 3 views.

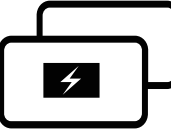
-  Parameters and set values for the ventilation programs
-  Graph view of signals and events
-  In the **On** state: Remaining device life if being supplied by battery
In the **Standby** state: Charging state of the internal battery in percent assuming a power supply

To switch to the next view in each case, tap the Views key again. The horizontal lines on the Views key are the number of available views.

5.4.4 Report menu (usage data)

Information about the parameters in this menu can be found in the table below.

PARAMETER	DESCRIPTION
Alarm list	Lists the alarms which have occurred. The log is retained when the alarm system or the device is switched off. The start and end of ventilation is recorded. The log is retained even if the device is disconnected from the power supply and the batteries are removed. The log can store 1,000 alarms. Once this capacity limit has been reached, the oldest alarm is deleted and the new alarm is saved.
Event list	Lists the events that have occurred.
Alarm/event list	Lists the alarms and events which have occurred in chronological order.
Parameter overview	Lists all parameters and set values for the up to 4 ventilation programs which can be configured.
Device usage	Obtain information here about the patient's therapy (duration, days used, program proportions) and about device usage (operating time, internal battery life remaining or charging state of internal battery in percent).
Trends	Access to the graphical displays of the therapy parameters

5.4.5 System menu (device settings)

Information about the parameters in this menu can be found in the table below.

PARAMETER	DESCRIPTION
Program settings	You can copy the settings for one ventilation program to another program here. You can enable ventilation programs for the patient here.
Circuit test	Perform a circuit test here on change of patient and as required. This checks for resistance, compliance and leaks (see "5.5 Configuring and enabling ventilation programs", page 22).
FiO ₂ cell	Activate or deactivate the FiO ₂ cell and calibrate the FiO ₂ cell here.
Flight mode	You can activate/deactivate flight mode here. With flight mode activated, all wireless communication (modem) is ended.

PARAMETER	DESCRIPTION
Export therapy data	Here you can export therapy data and save it to a USB-C flash drive, for example. A USB flash drive must be connected for exporting.
Device settings	You can configure the device here (see "Device settings submenu", page 21).
Device status	Obtain information here about the device (name, type, serial number of device and components, firmware version and internal batterie). If modem connected: information about modem (PIC, registration state, etc.)

Device settings submenu

PARAMETER	DESCRIPTION
Alarm volume	You can set the alarm level here. In doing so, you specify the minimum alarm volume the patient may set. The patient can then only set a louder level. 1= very quiet, 2= quiet, 3= loud, 4= very loud You can test the alarms here.
Display	You can set brightness, orientation, and the screen background here.
Language	You can set the language and, if required, another language for the alarm messages here.
Service timer	You can activate the reminder function for the next service here. Select the period for the next service. Once the service has been performed, you can reset the reminder function here.
Filter timer	You can activate and reset the filter change reminder function here.
Pressure unit	You can set the desired unit of pressure here.
Exit expert menu automatically	You can set here whether the expert menu is exited automatically if there is no input for an extended period.
Date and time	You can set the current date and time here.
Connectivity	You can activate the connection function and connect the modem here.
Delete therapy data	You can delete therapy data here (in Standby only).
Set factory settings	Here you can reset the device, including the alarms, to factory settings (in Standby only).

5.5 Configuring and enabling ventilation programs

You can preconfigure and enable up to four programs for the patient in the device. If the patient needs different ventilation settings during the day compared to during the night, for example, he or she can switch the program him or herself.

⚠ CAUTION***Risk of injury from programs being enabled incorrectly!***

Selecting an incorrect or non-configured program may result in incorrect ventilation settings, putting the patient at risk.

- ⇒ Only enable ventilation programs if they have been configured for the patient in question.
- ⇒ On change of patient, reset the device to factory settings.

-
1. Call up the **System > Program settings** menu.
 2. To copy settings from one program to another, select **Options**.
 3. To enable the desired programs for the patient, mark the **Available** button.

6 Hygiene treatment and servicing

6.1 Hygiene treatment

⚠ WARNING

Risk of infection when the device is used again!

If the device is used by several patients, infections may be transmitted to the next patient and the device contaminated.

- ⇒ Do not reuse disposables.
- ⇒ Use the breathing system filter.

⚠ WARNING

Risk of injury due to contaminated or infected circuit!

A contaminated or infected circuit may transmit contamination or infections to the next patient.

- ⇒ Do not reprocess disposable circuits.

⚠ WARNING

Risk of injury from inadequate cleaning!

Residues in the ventilator and accessories or bacterial contamination of the ventilator and its accessories may lead to infections and harm the patient.

- ⇒ Clean the ventilator and its accessories regularly and carefully in accordance with these instructions for use.

6.1.1 General information

- Wear appropriate safety gear (e.g. safety gloves) for the disinfecting process.
- Follow the instructions for use of the disinfectant used. Solutions containing alcohol (25 g ethanol (94 %-strength), 35 g propan-1-ol per 100 g) are suitable. Recommended: Mikrozid AF liquid or perform advanced Alcohol EP.
- Ensure careful, correct cleaning so that no cleaning agent residues remain. Rinse all parts with clean water.
- If the device is used for several patients, the use of a breathing system filter is mandatory.
- To prevent foreign bodies being taken in, ensure that new filters are inserted following cleaning, hygiene treatment, servicing or repair.
- Following a hygiene treatment by the authorized specialist dealer, the device is suitable for using again with other patients.

- The following gas route components may be contaminated following use of the device:
 - LMT 31494 Device outlet port
 - LMT 31497 Seal for FiO₂ cell
 - LMT 31496 Flow sensor
 - LMT 31505 Nonreturn valve, complete
 - LMT 31530 Sound insulation case, pressure side
 - LMT 31490 Blower
 - LMT 31525 Sound insulation case, intake side
 - LMT 31446 Central part of housing
 - WM 29389 Fine filter
 - LMT 31487 Coarse dust filter
 - LMT 31422 Filter holder

6.1.2 Cleaning intervals

INTERVAL	ACTION
Weekly	Clean device (see "6.1.3 Subjecting device to a hygiene treatment", page 24).
Monthly	Clean coarse dust filter (see "Cleaning coarse dust filter (gray filter)", page 24).
	Replace fine filter (see "Replacing fine filter (white filter)", page 24).
Every 6 months	Clean filter for cooling air fan (see "Cleaning filter for cooling air fan", page 25).
	Replace coarse dust filter (see "Cleaning coarse dust filter (gray filter)", page 24).
On change of patient	<ul style="list-style-type: none"> • Clean or replace the exhalation module. The black exhalation module (included in scope of delivery) is a disposable and must be replaced. The black translucent exhalation module (has to be ordered separately) is suitable for autoclaving. • Set device to factory settings.

6.1.3 Subjecting device to a hygiene treatment

CAUTION

Risk of injury from electric shock!

Ingress of liquids may lead to a short-circuit, injure the user and damage the device.

- ⇒ Disconnect the device from the power supply before the hygiene treatment.
- ⇒ Do not immerse the device and components in liquids.
- ⇒ Do not pour liquids over the device and components.

WARNING

Risk of injury from inadequate cleaning!

Ozone may attack and damage materials in the devices.

- ⇒ Clean device, accessories, and ventilation/patient interface only in accordance with the associated instructions for use.
- ⇒ Do not use ozone cleaning devices.

1. Wipe over the housing including the device outlet port, the power cable, and the display with a damp cloth. Use water or mild detergent.
2. Clean or replace the mask, circuit, coarse dust filter, fine filter, filter for the cooling air fan, and the breathing system filter (see " ", page 23).
3. Perform function check (see "6.2 Function check", page 25).

Cleaning coarse dust filter (gray filter)

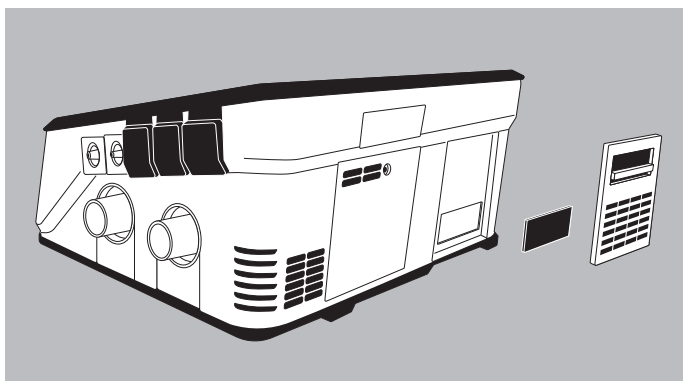

1. Open filter compartment flap.
2. Remove gray coarse dust filter.
3. Wash coarse dust filter under running water.
4. Allow coarse dust filter to dry.
5. Replace coarse dust filter in the holder.
6. Close filter compartment flap.

Replacing fine filter (white filter)

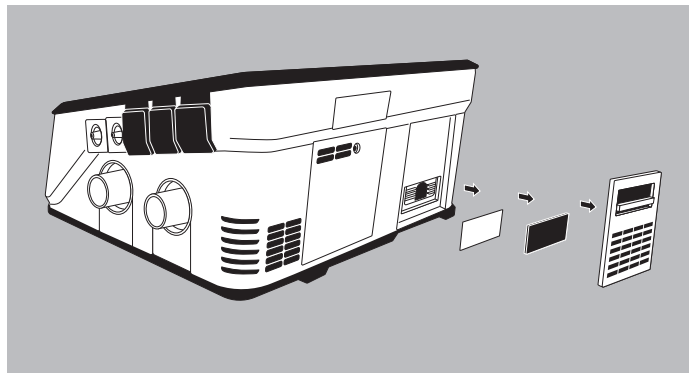

1. Open filter compartment flap.
2. Remove gray coarse dust filter.
3. Remove and replace white fine filter.
4. Replace coarse dust filter in the holder.
5. Close filter compartment flap.

Cleaning exhalation module

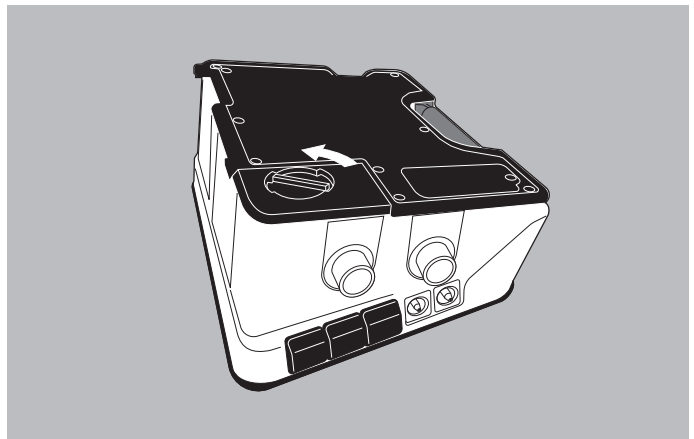

1. To open the exhalation module compartment on the rear of the device, turn the latch counterclockwise to the  symbol.
2. Remove cover.
3. Remove exhalation module.

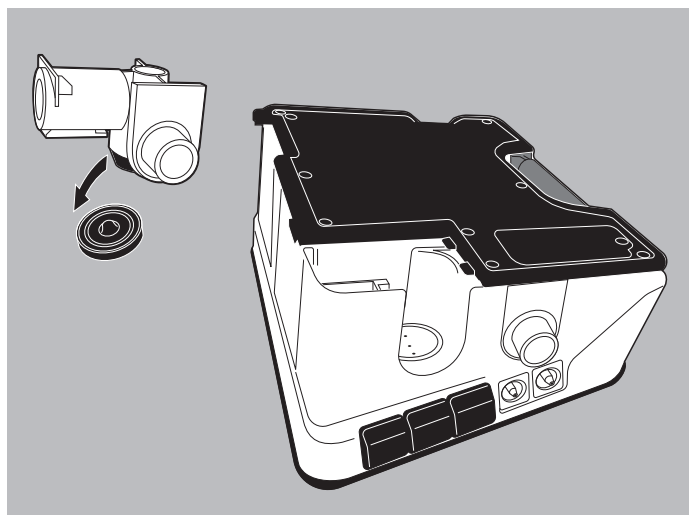

- i** Only the black translucent module is suitable for cleaning. The black module is a disposable and must be replaced.
- Remove membrane from the exhalation module.
 - Wipe over exhalation module and membrane with disinfectant.
Both parts can be disinfected in an autoclave at 134 °C and 3.15 bar with a process time of 5 minutes (maximum 50 cycles).
 - Check exhalation module for cracks and damage. If necessary: Replace exhalation module.
 - Leave exhalation module and membrane to dry.
 - Put membrane back on exhalation module.
 - Replace exhalation module in the compartment.
 - Close exhalation module compartment.

Cleaning filter for cooling air fan

- Open exhalation module compartment (see “[Cleaning exhalation module](#)”, page 24).

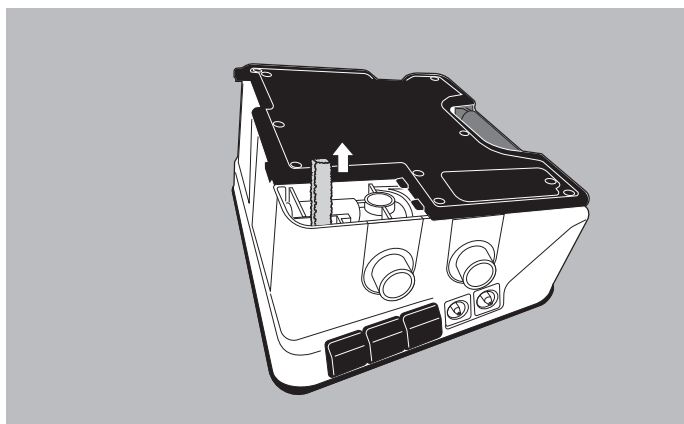

- Remove filter for cooling air fan.
- Wash filter under running water.
- Allow filter to dry.
- Replace filter in the holder.
- Close exhalation module compartment.

6.2 Function check

Carry out a function check before using the device for the first time, after every hygiene treatment, and after every repair, but at least every 6 months.

- Check device for external damage.
- Check connectors, cables, and circuit for external damage.
- Check accessories such as the breathing system filter, external batteries, and SpO₂ sensor for external damage.
Follow the associated instructions for use.

- Check that components are connected to the device correctly (see “[4.2 Connecting circuit](#)”, page 13).
- Connect the device to the power supply (see “[4.1 Setting up and connecting device](#)”, page 13).
- Switch on device (see “[4.5 Switching on device](#)”, page 15).
The device automatically performs a few function tests on the sensor system. If the device is fully functional, the start screen is displayed and the device switches to standby.
- Perform a circuit test (see: **System** > **Circuit test** menu).
If the circuit test is failed, proceed according to the troubleshooting table (see “[9 Faults](#)”, page 47).
- Seal the end of the circuit and start ventilation. A brief acoustic alarm must be audible on starting. The device automatically performs a few function tests.
The alarm key lights up yellow and red.
- Compare the pressure shown in the display with the prescribed pressure.
- Check the functionality of the batteries:
 - Disconnect the device from the power supply. The first external battery (if present) takes over energy supply (watch what is shown in display).
 - Disconnect the first external battery from the device. The second external battery (if present) takes over energy supply.
 - Disconnect the second external battery from the device. The internal battery takes over energy supply.
- Check the charging state of the batteries (see “[5.2.1 Views menu in the Patient menu](#)”, page 18).
If the batteries are not charged, leave the device connected to the power supply to charge batteries.
- If a FiO₂ cell is in use: Perform FiO₂ calibration (see “[5.2.3 System menu in the Patient menu](#)”, page 19).
- When using an SpO₂ sensor:
 - Check whether the sensor calculates measured values and displays them on the screen (SpO₂, pulse).
 - Check whether the symbol **SpO₂** in the status line lights up green.

Do not use a functional tester to assess the accuracy of an SpO₂ sensor or a pulse oximeter.

- If one of the items is not OK or pressure deviates by > 1 cmH₂O: Do not use device and contact your specialist dealer.
- If required: Check alarms (see “[6.3 Checking alarms](#)”, page 26).

6.3 Checking alarms

6.3.1 Non-specialist user (patient or relatives)

ALARM	ID NO.	REQUIREMENT	TEST
Leakage high (High level of leakage)	459	On a single circuit with valve: Alarm limit is set to a value <150 l/m With leakage circuit: Alarm limit is set to a value <60 l/m On a double circuit, 15 mm/22 mm: Alarm limit is set to a value <60 l/m On a double circuit, 10 mm: Alarm limit is set to a value ≤ 35 l/min	Leave circuit open at patient connection. Start ventilation. Wait at least 30 seconds, more alarms may occur during this period.
Pressure low (Low airway pressure, low pressure on inspiration)	457	Alarm limit is set to a value ≥ 6 cmH ₂ O	Leave circuit open at patient connection. Start ventilation.
Exhalation blocked (Obstruction)	757	Single circuit with valve is connected. <i>Alternatively</i> Double circuit is connected.	Connect test lung. Start ventilation. On a single circuit with valve: Seal exhalation opening of patient valve. On a double circuit: Take the circuit off the device and seal the connection.
Tidal volume low (Low volume exhaled)	450	Double circuit: Alarm limit is set.	Start ventilation. Take circuit off device. Wait 3 breaths.
FiO ₂ low (Oxygen concentration)	494	O ₂ cell is fitted and activated. Alarm limit is set. No external oxygen supply available.	Start ventilation.
Battery capacity low	551	Device is not connected to the power supply.	Start ventilation until the internal battery has 15 minutes' life remaining before it discharges completely.
Battery capacity critical	550	Device is not connected to the power supply.	Start ventilation until the internal battery has 5 minutes' life remaining before it discharges completely.
Energy supply via internal battery	584	None	Disconnect power cable from device. Disconnect the cable for the external batteries from the device.

6.3.2 Specialist user (physician or hospital nursing staff)

ALARM	ID NO.	REQUIREMENT	TEST
Constant pressure level	758	-	Set IPAP and EPAP/PEEP to the identical pressure level. Start ventilation. Wait 17 seconds.
Tidal volume low (Volume delivered)	450	Single circuit with valve connected	Connect test lung. Start ventilation. Read off volume delivered (VTi) Set alarm limit to a value above the volume delivered.
Pressure high (High airway pressure)	456	-	Connect test lung. Start ventilation. Read off current IPAP. Set alarm limit to a value below IPAP.

ALARM	ID NO.	REQUIREMENT	TEST
Rate low (<i>Hypoventilation</i>)	452	-	Connect test lung. Set PSV mode. Start ventilation. Read off current rate. Set alarm limit to a value above the rate displayed.
Tidal volume high (<i>High volume exhaled</i>)	451	-	Connect test lung. Start ventilation. Read off current VT/VTe. Set alarm limit to a value below the VT/VTe displayed.
Tidal volume low (<i>Low volume exhaled</i>)	450	Double circuit: Alarm limit set.	Connect test lung. Start ventilation. Take circuit off device.
TECHNICAL ALARMS			
Therapy ended	794	Therapy ended alarm is activated in the Alarms menu.	End therapy.
Maximum device pressure	825	-	Connect an external device to the patient connection opening to generate pressure. IPAP and external pressure generation together must be > 90 cmH ₂ O. Start external pressure generation. Start ventilation.
Pressure permanently low	755	Pressure controlled mode set	Start ventilation with an open circuit at the patient connection. Wait 15 breaths.
Tidal volume permanently low	756	Volume controlled mode or pressure controlled mode with target volume set	Start ventilation with a sealed circuit at the patient connection. Wait 15 breaths.
Exhalation blocked	757	Double circuit connected	Start ventilation. Seal off circuit.
No exhalation valve	753	Leakage circuit connected	Remove the exhalation valve from the circuit. Start ventilation. Wait 30 seconds.
Intake area blocked	759	-	Start ventilation. Block intake area.
Unable to reach flow	364	HFT mode set	Start ventilation. Seal mask interface.
Disconnection patient	465	HFT mode set	Start ventilation. Remove mask interface.
Disconnection patient	464	-	Start ventilation with an open circuit at the patient connection.
Disconnection device outlet	460	-	Start ventilation with an open circuit at the device outlet port.
Disconnection valve control pressure	798	Single circuit with valve connected	Start ventilation. Disconnect the circuit from the patient valve.
Pressure measuring tube	760	Single circuit with valve connected	Switch pressure measuring tube and valve control tube. Start ventilation.
Disconnection airway pressure	461	Single circuit with valve connected	Start ventilation. Disconnect pressure measuring tube.
Faulty circuit	795	-	Set and calibrate circuit. Connect a different circuit. Start ventilation.

6.4 Manual alarm test

A manual alarm test can be carried out to check the alarm audio system.

1. Call up the **System > Device settings > Alarm volume > Alarm test** menu.
2. Select volume and press the **Start** button. A signal tone is played once at the selected volume.
3. Confirm or negate whether you heard the signal tone.
If the signal tone is not audible, contact your specialist dealer.

If the primary alarm system fails, a second alarm system is activated.

During the manual alarm test, the audible tone is also transmitted via the remote alarm system.

6.5 Servicing

The device is designed for a service life of 10 years.

If the device is used beyond this period, it needs checking by the manufacturer or by an authorized specialist dealer.

The internal and the external battery must be replaced every 4 years or after 500 cycles.

The membrane of the nonreturn valve must be replaced every 4 years.

The blower must be replaced after an operating time of 35,000 h.

6.5.1 Replacing FiO₂ cell

The FiO₂ cell is continuously emptied as a result of contact with oxygen. If the FiO₂ cell is almost empty, a message will appear and the FiO₂ cell must be replaced.

Removing FiO₂ cell

Requirement: Device is switched off and disconnected from the power supply.

1. Undo 2 screws of the FiO₂ compartment on the rear of the device with a screwdriver.
2. Remove the cover of the FiO₂ compartment.

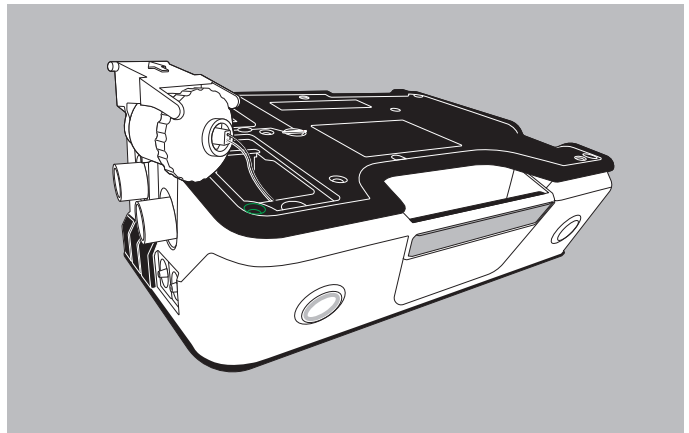

3. Remove the FiO₂ cell with the bracket from the compartment.
4. Disconnect the plug connector of the cable.

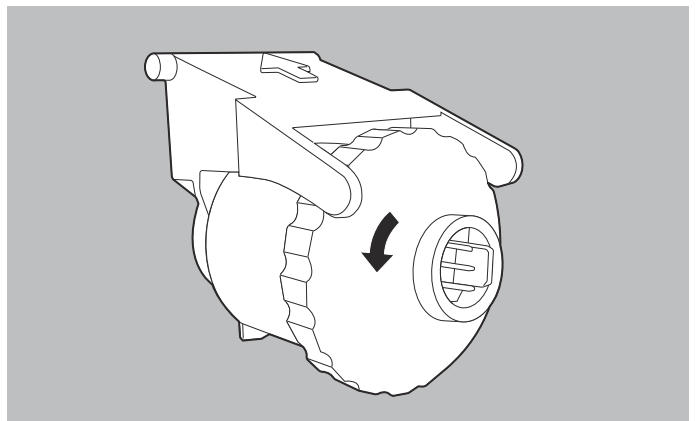

5. Unscrew FiO₂ cell from the bracket.

Fitting FiO₂ cell

1. Screw new FiO₂ cell into the bracket.
2. Insert the FiO₂ cell with the bracket into the compartment at a slight angle.
3. Connect the plug connector of the cable.
4. Insert FiO₂ cell fully until the catch engages.
5. Put on cover of the FiO₂ compartment.
6. Insert 2 screws and tighten up using a screwdriver.
7. Switch on device and calibrate FiO₂ cell (see "4.9 Calibrating FiO₂ cell", page 16).

6.6 Disposal

Do not dispose of the product or any batteries present with domestic waste. To dispose of it properly, contact a licensed, certified electronic waste disposal merchant. This address is available from your Environment Officer or from your local authority. The device packaging (cardboard and inserts) can be disposed of in paper recycling facilities.

7 Ventilation modes

7.1 General

Setting unit of pressure

1. Select the **Device settings > Unit of pressure** menu.
2. Set the required unit of pressure.

Modes with target volume or delivered volume

In modes in which a delivered volume or a target volume are set, take account of set therapy pressures. The set therapy pressures affect delivered volume and target volume.

Modes for respiratory support in line with ISO 80601-2-72

HFT mode and MPV mode are not respiration support modes within the meaning of standard ISO 80601-2-72. As no permanent and/or sealed connection is made between the corresponding patient interfaces and the patient's airway, some specifications such as disconnection detection do not apply.

7.2 CPAP mode

During therapy in CPAP mode, the device continuously supplies the patient with respiratory air at a constant positive pressure.

The graph shows the currently regulated airway pressure over time.

7.2.1 Adjustable parameters in CPAP mode

PARAMETER	ADJUSTABLE VALUES	DESCRIPTION
CPAP	4 -20 cmH ₂ O	You can select the pressure level here.
CPAP in circuits with valve only		
Trigger sensitivity on inspiration	1 – 10	Set trigger sensitivity here. 1: Highly sensitive 10: Not very sensitive
Trigger sensitivity on expiration	95 % – 5 %	Set trigger sensitivity on expiration here. Triggering is effected when the following values are reached by maximum flow: 95 %: Highly sensitive 5 %: Insensitive
Trigger lockout time on inspiration	0.2 s – 5 s	Trigger signals on inspiration are ignored during the set period.

7.3 HFT mode

In High Flow mode (HFT mode), the device pumps the set flow to an external humidifier suitable for HFT. This conditions the respiratory gas in terms of temperature and humidity. The patient connection is made using accessories suitable for HFT.

The graph shows the currently regulated airway pressure over time.

7.3.1 Parameters which can be adjusted in HFT mode

PARAMETER	ADJUSTABLE VALUES	DESCRIPTION
HFT	5 l/min to 60 l/min	In HFT mode, the device serves as a flow source for High Flow therapy.

7.4 S mode

In S mode, respiratory support is started and ended by the patient's spontaneous breathing. Fixed values can be set for pressure levels during inspiration and expiration.

The graph shows the currently regulated airway pressure over time.

7.4.1 Adjustable parameters in S mode

PARAMETER	ADJUSTABLE VALUES	DESCRIPTION
IPAP	4 – 50 cmH ₂ O	Set positive airway pressure on inspiration here.
EPAP	4 – 25 cmH ₂ O	Set positive airway pressure on expiration here.
Ti min	0.5 s – Ti max	Set the minimum duration of inspiration here.
Ti max	0.5 s – 4 s	Set the maximum duration of inspiration here.
Trigger sensitivity on inspiration	1 – 10 auto	Set trigger sensitivity here. 1: Highly sensitive 10: Not very sensitive auto: Device optimizes trigger sensitivity.
Trigger sensitivity on expiration	95 % – 5 %	Set trigger sensitivity on expiration here. Triggering is effected when the following values are reached by maximum flow on inspiration: 95 %: Highly sensitive 5 %: Insensitive
Target volume	On: 100 ml – 3,000 ml IPAP max: 4 cmH ₂ O to 60 cmH ₂ O Speed: 1 to 3	Speed of modification: • Level 1: 0.5 cmH ₂ O every 8 breaths • Level 2: 1.0 cmH ₂ O every 5 breaths • Level 3: 1.5 cmH ₂ O every breath
Pressure rise	1 2 3 4	Set the speed at which IPAP is reached here: • Level 1: 100 cmH ₂ O/s • Level 2: 80 cmH ₂ O/s • Level 3: 50 cmH ₂ O/s • Level 4: 20 cmH ₂ O/s
Pressure drop	1 2 3 4	Set the speed at which pressure is reduced to EPAP here: • Level 1: -100 cmH ₂ O/s • Level 2: -80 cmH ₂ O/s • Level 3: -50 cmH ₂ O/s • Level 4: -20 cmH ₂ O/s

7.5 ST mode

In ST mode, fixed values can be set for pressure levels during inspiration and expiration. In ST mode (S = spontaneous, T = timed), the device supports the patient's ventilation.

The patient can trigger on both inspiration and expiration. Both the patient's spontaneous breathing and the mechanical breaths triggered by the device

may predominate. If there is no spontaneous breathing, the device takes over ventilation at the set background frequency.

The graph shows the currently regulated airway pressure over time.

7.5.1 Adjustable parameters in ST mode

PARAMETER	ADJUSTABLE VALUES	DESCRIPTION
IPAP	4 – 50 cmH ₂ O	Set positive airway pressure on inspiration here.
EPAP	4 – 25 cmH ₂ O	Set positive airway pressure on expiration here.
rate	2 – 60/min	Set background rate per minute here.
Ti min	0.5 s – Ti max	Set the minimum duration of inspiration for spontaneous breaths here.
Ti max	0.5 s – 4 s	Set the maximum duration of inspiration for spontaneous breaths here.
Ti timed	auto 0.5 s – 4 s	Set the duration of inspiration for mandatory breaths here. On auto setting, the Ti min and Ti max limits also apply to the inspiration times during background ventilation.
Trigger sensitivity on inspiration	1 – 10 auto	Set trigger sensitivity here. 1: Highly sensitive 10: Not very sensitive auto: Device optimizes trigger sensitivity.
Trigger sensitivity on expiration	95 % – 5 %	Set trigger sensitivity on expiration here. Triggering is effected when the following values are reached by maximum flow on inspiration: 95 %: Highly sensitive 5 %: Insensitive
Trigger lockout time on inspiration	0.2 s – 5 s	Trigger signals on inspiration are ignored during the set period.
Target volume	On: 100 ml – 3,000 ml IPAP max: 4 cmH ₂ O to 60 cmH ₂ O Speed: 1 to 3	Speed of modification: • Level 1: 0.5 cmH ₂ O every 8 breaths • Level 2: 1.0 cmH ₂ O every 5 breaths • Level 3: 1.5 cmH ₂ O every breath
Pressure rise	1 2 3 4	Set the speed at which IPAP is reached here: • Level 1: 100 cmH ₂ O/s • Level 2: 80 cmH ₂ O/s • Level 3: 50 cmH ₂ O/s • Level 4: 20 cmH ₂ O/s
Pressure drop	1 2 3 4	Set the speed at which pressure is reduced to EPAP here: • Level 1: 100 cmH ₂ O/s • Level 2: 80 cmH ₂ O/s • Level 3: 50 cmH ₂ O/s • Level 4: 20 cmH ₂ O/s

7.6 T mode

In T mode, the device triggers all breaths. You can set fixed values for the pressure levels IPAP for inspiration and EPAP for expiration.

The graph shows the currently regulated airway pressure over time.

7.6.1 Adjustable parameters in T mode

PARAMETER	ADJUSTABLE VALUES	DESCRIPTION
IPAP	4 - 50 cmH ₂ O	Set positive airway pressure on inspiration here.
EPAP	4 - 25 cmH ₂ O	Set positive airway pressure on expiration here.
rate	2 – 60/min	Set ventilation rate per minute here.
Ti	0.5 – 4 s	Set inspiration time here.

PARAMETER	ADJUSTABLE VALUES	DESCRIPTION
Target volume	On: 100 ml – 3,000 ml IPAP max: 4 cmH ₂ O to 60 cmH ₂ O Speed: 1 to 3	Speed of modification: <ul style="list-style-type: none"> • Level 1: 0.5 cmH₂O every 8 breaths • Level 2: 1.0 cmH₂O every 5 breaths • Level 3: 1.5 cmH₂O every breath
Pressure rise	1 2 3 4	Set the speed at which IPAP is reached here: <ul style="list-style-type: none"> • Level 1: 100 cmH₂O/s • Level 2: 80 cmH₂O/s • Level 3: 50 cmH₂O/s • Level 4: 20 cmH₂O/s
Pressure drop	1 2 3 4	Set the speed at which pressure is reduced to EPAP here: <ul style="list-style-type: none"> • Level 1: -100 cmH₂O/s • Level 2: -80 cmH₂O/s • Level 3: -50 cmH₂O/s • Level 4: -20 cmH₂O/s

7.7 TTV-VAPS-AE mode

TTV-VAPS-AE mode is for leakage circuit only.

TTV-VAPS-AE mode combines:

- Pressure support
- Automatic control of pressure on expiration (autoEPAP)

- Automatic background frequency (auto rate)

Continuous control of background frequency auto rate (option) allows the patient to breathe spontaneously at any time.

The graph shows the currently regulated airway pressure over time.

7.7.1 Adjustable parameters in TTV-VAPS-AE mode

PARAMETER	ADJUSTABLE VALUES	DESCRIPTION
EPAP min	4 – 20 cmH ₂ O	Set minimum EPAP here.
EPAP max	4 – 20 cmH ₂ O	Set maximum EPAP here.
PS	0 – 46 cmH ₂ O	Set the pressure support as a delta value added to EPAP level.: Current EPAP value + PS
auto rate	On Off	Activate/deactivate automatic background frequency here. auto rate intervenes if the patient fails to trigger, monitors the volume delivered and increases background frequency if required.
rate	2 – 60/min	If auto rate is deactivated, set the background frequency here.
Ti min	0.5 s – Ti max	Set the minimum duration of inspiration for spontaneous breaths here.
Ti max	0.5 s – 4 s	Set the maximum duration of inspiration for spontaneous breaths here.
Ti timed	auto 0.5 s – 4 s	Set the duration of inspiration for mandatory breaths here. On auto setting, the Ti min and Ti max limits also apply to the inspiration times during background ventilation.
Trigger sensitivity on inspiration	auto 1-10	Set trigger sensitivity here. 1: Highly sensitive 10: Not very sensitive auto: Device optimizes trigger sensitivity.
Trigger sensitivity on expiration	95 % – 5 %	Set trigger sensitivity on expiration here. Triggering is effected when the following values are reached by maximum flow: 95 %: Highly sensitive 5 %: Insensitive

PARAMETER	ADJUSTABLE VALUES	DESCRIPTION
Trigger lockout time on inspiration	Off 0.20 s – 5.00 s	Trigger signals on inspiration are ignored during the set period.
Target volume	Off On: 100 ml – 3,000 ml PSmax: 0 cmH ₂ O to 46 cmH ₂ O Speed: 1 to 3	Speed of modification: <ul style="list-style-type: none"> • Level 1: 0.5 cmH₂O every 8 breaths • Level 2: 1.0 cmH₂O every 5 breaths • Level 3: 1.5 cmH₂O every breath
Pressure rise	1 2 3 4	Set the speed at which IPAP (current EPAP + PS value) is reached here: <ul style="list-style-type: none"> • Level 1: 100 cmH₂O/s • Level 2: 80 cmH₂O/s • Level 3: 50 cmH₂O/s • Level 4: 20 cmH₂O/s
Pressure drop	1 2 3 4	Set the speed at which pressure is reduced to EPAP here: <ul style="list-style-type: none"> • Level 1: 100 cmH₂O/s • Level 2: 80 cmH₂O/s • Level 3: 50 cmH₂O/s • Level 4: 20 cmH₂O/s

7.8 PSV mode

In PSV mode, fixed values can be set for the pressure levels during inspiration and expiration. In PSV mode, the device supports the patient in his or her ventilation, the patient can trigger on both inspiration and expiration. Both the patient's spontaneous breathing and the mechanical breaths triggered by the device may predominate.

The graph shows the currently regulated airway pressure over time.

7.8.1 Adjustable values in PSV mode

PARAMETER	ADJUSTABLE VALUES	DESCRIPTION
IPAP	4 – 50 cmH ₂ O (leakage circuit) 4 – 60 cmH ₂ O (single or double circuit with valve)	Set positive airway pressure on inspiration here.
PEEP	4 – 25 cmH ₂ O (leakage circuit) 0 – 25 cmH ₂ O (single or double circuit with valve)	Set positive airway pressure on expiration here.
rate	2 – 60/min	Set background frequency (rate) per minute here.
Ti min	0.5 s – Ti max	Set the minimum duration of inspiration for spontaneous breaths here.
Ti max	0.5 s – 4 s	Set the maximum duration of inspiration for spontaneous breaths here.
Ti timed	auto 0.5 s – 4 s	Set the duration of inspiration for mandatory breaths here. On auto setting, the Ti min and Ti max limits also apply to the inspiration times during background ventilation.
Trigger sensitivity on inspiration	1 – 10 auto	Set trigger sensitivity here: 1: Highly sensitive 10: Not very sensitive auto: Device optimizes trigger sensitivity.
Trigger lockout time on inspiration	0.2 s – 5 s	Trigger signals on inspiration are ignored during the set period.

PARAMETER	ADJUSTABLE VALUES	DESCRIPTION
Target volume	On: 100 ml – 3,000 ml IPAP max: 4 cmH ₂ O to 60 cmH ₂ O Speed: 1 to 3	Speed of modification: <ul style="list-style-type: none"> • Level 1: 0.5 cmH₂O every 8 breaths • Level 2: 1.0 cmH₂O every 5 breaths • Level 3: 1.5 cmH₂O every breath
Pressure rise	1 2 3 4	Set the speed at which IPAP is reached here: <ul style="list-style-type: none"> • Level 1: 100 cmH₂O/s • Level 2: 80 cmH₂O/s • Level 3: 50 cmH₂O/s • Level 4: 20 cmH₂O/s
Pressure drop (leakage ventilation only)	1 2 3 4	Set the speed at which pressure is reduced to PEEP here: <ul style="list-style-type: none"> • Level 1: -100 cmH₂O/s • Level 2: -80 cmH₂O/s • Level 3: -50 cmH₂O/s • Level 4: -20 cmH₂O/s

7.9 aPCV mode

In aPCV mode, fixed values can be set for the pressure levels during inspiration and expiration. In aPCV mode, the device supports the patient in his or her ventilation, the patient can trigger on inspiration. Both the patient's spontaneous breathing and the mechanical breaths triggered by the device may predominate.

The graph shows the currently regulated airway pressure over time.

7.9.1 Adjustable parameters in aPCV mode

PARAMETER	ADJUSTABLE VALUES	DESCRIPTION
IPAP	4 – 50 cmH ₂ O (leakage circuit) 4 – 60 cmH ₂ O (single or double circuit with valve)	Set positive airway pressure on inspiration here.
PEEP	4 – 25 cmH ₂ O (leakage circuit) 0 – 25 cmH ₂ O (single or double circuit with valve)	Set positive airway pressure on expiration here.
rate	2 – 60/min	Set ventilation frequency (rate) per minute here.
Ti	0.5 – 4 s	Set the fixed inspiration time here.
Trigger sensitivity on inspiration	1 – 10 auto	Set trigger sensitivity here: 1: Highly sensitive 10: Not very sensitive auto: Device optimizes trigger sensitivity.
Trigger lockout time on inspiration	0.2 s – 5 s	Trigger signals on inspiration are ignored during the set period.

PARAMETER	ADJUSTABLE VALUES	DESCRIPTION
Target volume	On: 100 ml – 3,000 ml IPAP max: 4 cmH ₂ O to 60 cmH ₂ O Speed: 1 to 3	Speed of modification: <ul style="list-style-type: none"> • Level 1: 0.5 cmH₂O every 8 breaths • Level 2: 1.0 cmH₂O every 5 breaths • Level 3: 1.5 cmH₂O every breath
Pressure rise	1 2 3 4	Set the speed at which IPAP is reached here: <ul style="list-style-type: none"> • Level 1: 100 cmH₂O/s • Level 2: 80 cmH₂O/s • Level 3: 50 cmH₂O/s • Level 4: 20 cmH₂O/s
Pressure drop	1 2 3 4	Set the speed at which pressure is reduced to EPAP here: <ul style="list-style-type: none"> • Level 1: -100 cmH₂O/s • Level 2: -80 cmH₂O/s • Level 3: -50 cmH₂O/s • Level 4: -20 cmH₂O/s

7.10 PCV mode

In PCV mode, the device triggers all breaths. You can set fixed values for the IPAP and PEEP pressure levels.

The graph shows the currently regulated airway pressure over time.

7.10.1 Adjustable parameters in PCV mode

PARAMETER	ADJUSTABLE VALUES	DESCRIPTION
IPAP	4 – 50 cmH ₂ O (leakage circuit) 4 – 60 cmH ₂ O (single or double circuit with valve)	Set positive airway pressure on inspiration here.
PEEP	4 – 25 cmH ₂ O (leakage circuit) 0 – 25 cmH ₂ O (single or double circuit with valve)	Set positive airway pressure on expiration here.
rate	2 – 60/min	Set ventilation frequency (rate) per minute here.
Ti	0.5 s – 4 s	Set the fixed inspiration time here.

7.11 aVCV mode

In aVCV mode, fixed values can be set for volume (V_t) during inspiration and for the lower pressure level during expiration.

In aVCV mode, the device supports the patient in his or her ventilation, the patient can trigger on inspiration. Both the patient's spontaneous breathing and the mechanical breaths triggered by the device may predominate.

The graph shows the currently regulated airway pressure over time.

7.11.1 Adjustable parameters in aVCV mode

PARAMETER	ADJUSTABLE VALUES	DESCRIPTION
VT	100 ml – 3,000 ml	Set the volume delivered (V _t) here.
PEEP	0 – 25 cmH ₂ O	Set positive airway pressure on expiration here.
rate	2 – 60/min	Set background frequency (rate) per minute here.

PARAMETER	ADJUSTABLE VALUES	DESCRIPTION
T _i	0.5 s – 4 s	Set inspiration time here. Spontaneous breathing: Inspiration finishes no later than when T _i elapses. Mandatory breath: T _i is fixed.
Trigger on inspiration	1 – 10 auto	Set trigger sensitivity here: 1: Highly sensitive 10: Not very sensitive auto: Device optimizes trigger sensitivity.
Trigger lockout time	0.2 s – 5 s	Trigger signals on inspiration are ignored during the set period.

7.12 VCV mode

In VCV mode, the device triggers all breaths. You can set fixed values for volume (V_t) and PEEP.

The graph shows the currently regulated airway pressure over time.

7.12.1 Adjustable parameters in VCV mode

PARAMETER	ADJUSTABLE VALUES	DESCRIPTION
V _T	100 ml – 3,000 ml	Set the volume delivered (V _t) here.
PEEP	0 – 25 cmH ₂ O	Set positive airway pressure on expiration here.
rate	2 – 60/min	Set ventilation frequency (rate) per minute here.
T _i	0.5 s – 4 s	Set the fixed inspiration time here.

7.13 P-SIMV mode

In P-SIMV mode, it is possible to set both pressure support for spontaneous breaths and a fixed value for the pressure level on inspiration during mandatory breaths. In addition, the lower pressure level is specified. The mandatory breaths are triggered by the frequency setting.

The graph shows the currently regulated airway pressure over time.

Inspiration and expiration phases are generally specified by the patient's spontaneous breathing, by the trigger parameter, and by parameters F, T_i min, T_i max, and T_i.

7.13.1 Adjustable parameters in P-SIMV mode

PARAMETER	ADJUSTABLE VALUES	DESCRIPTION
PS	4 – 46 cmH ₂ O (leakage circuit) 4 – 60 cmH ₂ O (single or double circuit with valve)	Set pressure support during spontaneous breaths here.
IPAP	4 – 50 cmH ₂ O (leakage circuit) 4 – 60 cmH ₂ O (single or double circuit with valve)	Set positive airway pressure on inspiration here.
PEEP	4 – 25 cmH ₂ O (leakage circuit) 0 – 25 cmH ₂ O (single or double circuit with valve)	Set positive airway pressure on expiration here.
rate	2 – 60/min	Set ventilation frequency (rate) per minute here.
T _i min	0.5 s – T _i max	Set the minimum duration of inspiration for spontaneous breaths here.

PARAMETER	ADJUSTABLE VALUES	DESCRIPTION
Ti max	0.5 s – 4 s	Set the maximum duration of inspiration for spontaneous breaths here.
Ti	0.5 s – 4 s	Set the duration of inspiration for mandatory breaths here.
Trigger sensitivity on inspiration	1 – 10 auto	Set trigger sensitivity here: 1: Highly sensitive 10: Not very sensitive auto: Device optimizes trigger sensitivity.
Trigger sensitivity on expiration	95 % – 5 %	Set trigger sensitivity on expiration here. Triggering is effected when the following values are reached by maximum flow: 95 %: Highly sensitive 5 %: Insensitive
Trigger lockout time on inspiration	0.2 s – 5 s	Trigger signals on inspiration are ignored during the set period.
Pressure rise	1 2 3 4	Set the speed at which IPAP is reached here: <ul style="list-style-type: none"> • Level 1: 100 cmH₂O/s • Level 2: 80 cmH₂O/s • Level 3: 50 cmH₂O/s • Level 4: 20 cmH₂O/s

7.14 V-SIMV mode

In V-SIMV mode, it is possible to set both pressure support for spontaneous breaths and a fixed volume for the mandatory breaths. In addition, the lower pressure level is specified. The mandatory breaths are triggered by the frequency setting.

Inspiration and expiration phases are generally specified by the patient's spontaneous breathing, by the trigger parameter, and by parameters F, Ti min, Ti max, and Ti. The graph shows the currently regulated airway pressure over time.

7.14.1 Adjustable parameters in V-SIMV mode

PARAMETER	ADJUSTABLE VALUES	DESCRIPTION
VT	100 ml – 3,000 ml	Set the volume delivered (V_t) here.
PS	4 – 46 cmH ₂ O (leakage circuit) 4 – 60 cmH ₂ O (single or double circuit with valve)	Set pressure support during spontaneous breaths here.
PEEP	4 – 25 cmH ₂ O (leakage circuit) 0 – 25 cmH ₂ O (single or double circuit with valve)	Set positive airway pressure on expiration here.
rate	2 – 60/min	Set background frequency (rate) per minute here.
Ti min	0.5 s – T _i max	Set the minimum duration of inspiration for spontaneous breaths here.
Ti max	0.5 s – 4 s	Set the maximum duration of inspiration for spontaneous breaths here.
Ti	0.5 s – 4 s	Set the duration of inspiration for mandatory breaths here.
Trigger sensitivity on inspiration	1 – 10 auto	Set trigger sensitivity here: 1: Highly sensitive 10: Not very sensitive auto: Device optimizes trigger sensitivity.

PARAMETER	ADJUSTABLE VALUES	DESCRIPTION
Trigger sensitivity on expiration	95 % – 5 %	Set trigger sensitivity on expiration here. Triggering is effected when the following values are reached by maximum flow: 95 %: Highly sensitive 5 %: Insensitive
Trigger lockout time on inspiration	0.2 s – dynamic	Trigger signals on inspiration are ignored during the set period.
Pressure rise	1 2 3 4	Set the speed at which IPAP is reached here: • Level 1: 100 cmH ₂ O/s • Level 2: 80 cmH ₂ O/s • Level 3: 50 cmH ₂ O/s • Level 4: 20 cmH ₂ O/s

7.15 MPVp mode

MPV mode (mouthpiece ventilation mode) is a spontaneous breathing mode in which the patient decides freely when to get breathing support. A pressure level on inspiration and an inspiration time are set. The graph shows the currently regulated airway pressure over time.

7.15.1 Adjustable parameters in MPVp mode

PARAMETER	ADJUSTABLE VALUES	DESCRIPTION
IPAP	4 – 50 cmH ₂ O (leakage circuit) 4 – 60 cmH ₂ O (single or double circuit with valve)	Set positive airway pressure on inspiration here.
Ti	0.5 s – 4 s	Set inspiration time here. Spontaneous breathing: Inspiration finishes no later than when T _i elapses.
Trigger sensitivity on inspiration	1 – 10	Set trigger sensitivity here: 1: Highly sensitive 10: Not very sensitive
Trigger lockout time on inspiration	0.2 s – 5 s	Trigger signals on inspiration are ignored during the set period.
Pressure rise	1 2 3 4	Set the speed at which IPAP is reached here: • Level 1: 60 cmH ₂ O/s • Level 2: 45 cmH ₂ O/s • Level 3: 30 cmH ₂ O/s • Level 4: 15 cmH ₂ O/s

7.16 MPVv mode

MPV mode (mouthpiece ventilation mode) is a spontaneous breathing mode in which the patient decides freely when to get breathing support. A volume on inspiration and a pressure level on inspiration are set.

The graph shows the currently regulated airway pressure over time.

7.16.1 Adjustable parameters in MPVv mode

PARAMETER	ADJUSTABLE VALUES	DESCRIPTION
Volume	100 ml – 3,000 ml	Set the volume delivered (V_t) here.
IPAP	4 – 50 cmH ₂ O (leakage circuit) 4 – 60 cmH ₂ O (single or double circuit with valve)	Set positive airway pressure on inspiration here.
Trigger sensitivity on inspiration	1 – 10	Set trigger sensitivity here: 1: Highly sensitive 10: Not very sensitive
Trigger lockout time on inspiration	0.2 s – 5 s	Trigger signals on inspiration are ignored during the set period.
Pressure rise	1 2 3 4	Set the speed at which IPAP is reached here: <ul style="list-style-type: none"> • Level 1: 60 cmH₂O/s • Level 2: 45 cmH₂O/s • Level 3: 30 cmH₂O/s • Level 4: 15 cmH₂O/s

7.17 Overview of available ventilation modes in the circuits

MODES	CIRCUITS		
	Leakage circuit Ø 22 mm, 15 mm	Single circuit with valve Ø 22 mm, 15 mm	Double circuit Ø 22 mm, 15 mm
CPAP	X	X	X
HFT	X	X	X
S	X		
S/T	X		
T	X		
TTV-VAPS-AE	X		
PSV	X	X	X
aPCV	X	X	X
PCV	X	X	X
aVCV		X	X
VCV		X	X
P-SIMV	X	X	X
V-SIMV	X	X	X
MPVp	X	X	X
MPVv	X	X	X

8 Alarms





A distinction is made between two types of alarm: Physiological alarms relate to ventilation of the patient. Technical alarms relate to configuration of the device. The technical alarms are active and cannot be configured.





8.1 Sequence in which alarms are displayed

Alarms are divided into the three priority levels low , medium , and high .

If several alarms are triggered simultaneously, the highest-priority alarm is always shown first. The lower-priority alarm is retained and is displayed again once the higher-priority alarm has been rectified.

8.2 Muting alarms

FUNCTION	ACTION
Acknowledge alarm	Press alarm acknowledgement key  briefly. If the alarm persists, the alarm is muted for 120 seconds. The fault continues to be displayed in the status line and the alarm acknowledgement key  flashes until the fault has been rectified.
Mute all acoustic alarms for 2 minutes	Press and hold alarm acknowledgement key  .
Suspend alarm muting	Press alarm acknowledgement key  again briefly.

DISPLAY	CODE	CAUSE	ACTION
Apnea 	458	No spontaneous breathing within set time.	Check therapy and alarm settings.
Pressure high 	456	Maximum pressure exceeded.	Check therapy and alarm settings.
Pressure low 	457	Minimum therapy pressure undershot.	Clean/change dirty filters.
		Patient/ventilator interface leaking.	Re-adjust patient/ventilator interface.
		Patient/ventilator interface defective.	Replace patient/ventilator interface.
Rate high 	453	Maximum respiratory rate exceeded.	Check therapy and alarm settings.

8.3 Configuring physiological alarms

All physiological alarms are deactivated on delivery or when the device is reset to factory settings. The attending physician can decide which physiological alarms are activated and make the alarm settings suitable for the patient. Various alarms can be configured depending on the ventilation mode selected.

Following a power supply outage of < 30 seconds, the set alarm settings are restored automatically.

WARNING

Risk of injury due to extreme alarm limit settings!

Alarm limits set to an extreme value may make the alarm system unusable and put the patient at risk.

⇒ Set sensible alarm limits.

















WARNING





Risk of injury due to different alarm presets in different clinical spheres!

All physiological alarms are deactivated on delivery or on resetting the device to factory settings. It can put the patient at risk if different alarm settings are used in different clinical spheres.



⇒ Make identical alarm settings in different spheres.







⇒ Before using the device, check whether the alarm presets are suitable for the patient.

DISPLAY	CODE	CAUSE	ACTION
Rate low 	452	Minimum respiratory rate undershot.	Check therapy and alarm settings.
Leakage high 	459	Leak	Check connection from device to patient/ventilator interface at the patient via the circuit. Check that the patient/ventilator interface is in position correctly.
Minute volume high 	455	Maximum minute volume exceeded.	Check therapy and alarm settings.
Minute volume low 	454	Minimum minute volume undershot.	Check therapy and alarm settings.
PEEP high 	469	End of exhalation pressure high.	Check therapy and alarm settings.
Tidal volume on exp. low 	470	Minimum exhalation volume undershot.	Check therapy and alarm settings.
Tidal volume on exp. high 	471	Maximum exhalation volume exceeded.	Check therapy and alarm settings.
Minute volume on exp. low 	472	Minimum minute volume on exhalation undershot.	Check therapy and alarm settings.
Minute volume on exp. high 	473	Maximum minute volume on exhalation exceeded.	Check therapy and alarm settings.
Tidal volume on insp. low 	474	Minimum tidal volume on inspiration undershot.	Check therapy and alarm settings.
Tidal volume on insp. high 	475	Maximum tidal volume on inspiration exceeded.	Check therapy and alarm settings.
Minute volume on insp. low 	476	Minimum minute volume on inspiration undershot.	Check therapy and alarm settings.
Minute volume on insp. high 	477	Maximum minute volume on inspiration exceeded.	Check therapy and alarm settings.
Pulse high 	493	Ventilation parameter settings not suitable (upper alarm setting for patient pulse frequency exceeded).	Check therapy and alarm settings.
		Alarm settings implausible	
Pulse low 	492	Alarm settings implausible (lower alarm setting for patient's pulse frequency undershot).	Check therapy and alarm settings.
SpO ₂ high 	491	Upper alarm setting for patient's oxygen saturation exceeded.	Check therapy and alarm settings.

















DISPLAY	CODE	CAUSE	ACTION
SpO ₂ low 	490	Patient/ventilator interface faulty or defective.	Check patient/ventilator interface and replace if necessary.
		Oxygen input faulty or inadequate.	Check therapy and alarm settings.
		Ventilation parameter settings not suitable.	
		Alarm settings implausible (lower alarm setting for patient's oxygen saturation undershot).	
Tidal volume low 	450	Leak in circuit.	Find and eliminate leak. If necessary: Replace circuit.
		Leak in pneumatic unit (oxygen sensor or exhalation module).	Check oxygen sensor or exhalation module and fit correctly. Perform circuit test (see 4.8, p. 16).
		Patient breathing as well.	Check therapy settings.
		Filter dirty.	Clean/change filter.
		Patient/ventilator interface leaking.	Adjust headgear/headband so that the patient/ventilator interface seals.
		Patient/ventilator interface defective.	Replace patient/ventilator interface.
		Settings implausible (lower alarm setting for tidal volume undershot).	Check therapy and alarm settings.
		Minimum volume is not reached within the specified time in MPVv mode.	Check therapy and alarm settings.
Tidal volume high 	451	Patient breathing as well.	Check therapy settings.
FiO ₂ low 	494	Oxygen flow set too low.	Check whether the prescribed oxygen flow is set correctly at the oxygen source. Check settings.
		Leak	Find and eliminate leak.
		Oxygen supply interrupted.	Check oxygen supply and connections.
		Oxygen sensor incorrectly calibrated.	Calibrate oxygen sensor.
FiO ₂ high 	495	Oxygen input too high due to incorrectly-set oxygen flow.	Check whether the prescribed oxygen flow is set correctly at the oxygen source. Check settings.
		Oxygen sensor incorrectly calibrated.	Calibrate oxygen sensor.

8.4 Technical alarms





DISPLAY	CODE	CAUSE	ACTION
Service necessary. Please get in touch with your specialist dealer/contact.	Various	Technical fault which can only be eliminated by an authorized specialist dealer.	Have device repaired.
Display error 	173	Display not working.	To restart the device, press the on/off key and the alarm acknowledgement key simultaneously.
Intake air temperature high 	262	Ambient temperature too high.	Operate device at an ambient temperature of 5 °C to 40 °C.

DISPLAY	CODE	CAUSE	ACTION
Main board temperature high 	263	Ambient temperature too high.	Operate device at an ambient temperature of 5 °C to 40 °C.
Computer module temperature high 	264	Ambient temperature too high.	Operate device at an ambient temperature of 5 °C to 40 °C.
Unable to reach flow 	364	Set flow not reached.	Check flow setting and accessories.
Disconnection device outlet port 	460	Circuit is not connected to the device correctly or is not connected at all.	Check circuit and connections.
Disconnection airway pressure 	461	Pressure measuring tube is not connected to the device correctly or is not connected at all.	Check pressure measuring tube.
Disconnection exhalation module 	463	Circuit and/or exhalation module is not connected to the device correctly or is not connected at all.	Check circuit, connections, and exhalation module.
Disconnection patient 	464	Device operated with open patient/ventilator interface (mask not applied). Circuit is not connected to the device correctly or is not connected at all.	Check circuit, connections, and patient/ventilator interface at the patient.
Life of the internal battery soon at an end 	542	The service life of the internal battery will soon be reached.	Contact your specialist dealer. Have internal battery replaced.
Life of battery E1/2 soon at an end 	543 544	The service life of the external battery will soon be reached.	Replace battery.
Temperature of battery E1 critically high 	547	External battery 1 too warm.	Battery will switch off due to temperature. Operate device at an ambient temperature of 5 °C to 40 °C.
Temperature of battery E2 critically high 	548	External battery 2 too warm.	Battery will switch off due to temperature. Operate device at an ambient temperature of 5 °C to 40 °C.
Error internal battery 	549	Internal battery defective.	Contact your specialist dealer. Have internal battery replaced.
Battery capacity critical 	550	Battery discharged (remaining battery life: 5 minutes)	Connect the device to the power supply.
Battery capacity low 	551	Battery discharged (remaining battery life: 15 minutes)	Connect the device to the power supply.
No internal battery 	553	No internal battery.	Contact your specialist dealer. Have internal battery inserted.

DISPLAY	CODE	CAUSE	ACTION
Temperature of internal battery critically high 	555	Internal battery too warm.	Battery will switch off due to temperature. Operate device at an ambient temperature of 5 °C to 40 °C.
Internal battery overheated 	556	Internal battery overheated.	Battery has switched off due to temperature. Operate device at an ambient temperature of 5 °C to 40 °C.
Unable to charge internal battery 	558	Internal battery defective.	Contact your specialist dealer. Have battery replaced.
Temperature of internal battery high 	559	Internal battery too warm.	Operate device at an ambient temperature of 5 °C to 40 °C.
Temperature of internal battery low 	560	Internal battery too cold.	Operate device at an ambient temperature of 5 °C to 40 °C.
Life of internal battery at an end 	561	Internal battery life at an end.	Contact your specialist dealer. Have battery replaced.
E1 battery life at an end 	562	External battery 1 life at an end.	Replace battery.
E2 battery life at an end 	563	External battery 2 life at an end.	Replace battery.
Battery E1 overheated 	564	External battery 1 overheated.	Battery has switched off due to temperature. Operate device at an ambient temperature of 5 °C to 40 °C.
Battery E2 overheated 	565	External battery 2 overheated.	Battery has switched off due to temperature. Operate device at an ambient temperature of 5 °C to 40 °C.
Unable to charge battery E1 	566	External battery 1 defective.	Contact your specialist dealer.
Unable to charge battery E2 	567	External battery 2 defective.	Contact your specialist dealer.
Temperature of battery E1 high 	568	External battery 1 too warm.	Operate device at an ambient temperature of 5 °C to 40 °C.
Temperature of battery E2 high 	569	External battery 2 too warm.	Operate device at an ambient temperature of 5 °C to 40 °C.
Temperature of battery E1 low 	570	External battery 1 too cold.	Operate device at an ambient temperature of 5 °C to 40 °C.

DISPLAY	CODE	CAUSE	ACTION
Temperature of battery E2 low 	571	External battery 2 too cold.	Operate device at an ambient temperature of 5 °C to 40 °C.
Error internal battery communication 	572	Internal battery defective. Device defective.	Contact your specialist dealer.
Error battery E1 communication 	573	External battery 1 defective. Device defective.	Contact your specialist dealer.
Error battery E2 communication 	574	External battery 2 defective. Device defective.	Contact your specialist dealer.
Error battery E1 	575	External battery 1 defective.	Contact your specialist dealer.
Error battery E2 	576	External battery 2 defective.	Contact your specialist dealer.
Error internal battery temperature 	577	Ambient temperature too high.	Operate device at an ambient temperature of 5 °C to 40 °C.
Error battery E1 temperature 	578	Ambient temperature too high.	Operate device at an ambient temperature of 5 °C to 40 °C.
Error battery E2 temperature 	579	Ambient temperature too high.	Operate device at an ambient temperature of 5 °C to 40 °C.
Power outage 	580	Power supply outage.	Use alternative ventilation option.
Energy supply via internal battery 	581	Power supply outage.	Check power cable is securely connected. Check function of socket.
		External battery and power supply not connected.	Note remaining battery life (see 3.6.3, p. 10). If necessary: Connect power supply.
No exhalation valve 	753	No exhalation valve.	Check circuit and patient interface. Connect exhalation valve.
Pressure permanently low 	755	Mask leakage too high.	Check and correct position of mask.
Tidal volume permanently low 	756	Settings implausible.	Check therapy and alarm settings.
Exhalation blocked 	757	Exhaled air outlet is blocked.	Check exhalation valve and exhalation module.
Constant pressure level 	758	Respiratory frequency or set pressure difference too low.	Check therapy settings.
Intake area blocked 	759	Intake area blocked.	Keep intake area free.

DISPLAY	CODE	CAUSE	ACTION
Pressure measuring tube and valve control tube switched 	760	Valve control tube and pressure measuring tube switched.	Check valve control tube and pressure measuring tube and connections are connected correctly (see 4.2.3, p. 14).
		Valve control tube kinked.	Check valve control tube for blockages and damage. If necessary: Replace valve control tube.
Error FiO ₂ cell 	770	FiO ₂ cell defective.	Replace FiO ₂ cell (see 4.10, p. 16).
No FiO ₂ cell 	771	No FiO ₂ cell fitted.	Fit FiO ₂ cell (see 4.10, p. 16).
FiO ₂ cell empty 	773	FiO ₂ cell empty.	Replace FiO ₂ cell (see 4.10, p. 16).
Blower temperature high 	789	Blower temperature too high. Cooling air filter blocked.	Cool device immediately or therapy will end. Check cooling air filter. If necessary: Have cooling air filter replaced by specialist dealer.
SpO ₂ signal weak 	792	SpO ₂ sensor not connected to the finger correctly.	Check connection with the finger. If alarm persists: Contact your specialist dealer.
SpO ₂ signal weak 	790	Signal interfered with by nail varnish or contaminants.	Remove nail varnish. Clean finger.
SpO ₂ sensor removed 	791	SpO ₂ sensor removed.	To monitor SpO ₂ and pulse, reconnect SpO ₂ sensor. If the alarm persists: Replace SpO ₂ sensor.
SpO ₂ cable removed 	793	SpO ₂ cable removed.	To monitor SpO ₂ and pulse, reconnect SpO ₂ cable.
Therapy ended 	794	Device is switched off.	Switch device back on.
Faulty circuit 	795	Circuit with valve selected. No circuit with valve connected.	Change circuit. Have settings checked by attending physician.
		Leakage circuit selected, circuit with valve connected.	Change circuit. Have settings checked by attending physician.
		Pressure measuring tube not connected correctly.	Check tubing.
		Circuit defective.	Check circuit and connections. If necessary: Replace circuit.
Re-inhalation 	796	Valve does not open in exhalation (medication has caused it to stick, for example).	Check circuit and connections. If necessary: Replace circuit.
		Patient's re-inhalation volume excessive at high frequency.	
Disconnection valve control pressure 	798	Circuit is not connected to the device correctly or is not connected at all.	Check circuit and connections. If necessary: Replace circuit.
Blower overheated 	799	Blower has overheated.	Therapy will end. Allow device to cool down.

DISPLAY	CODE	CAUSE	ACTION
Maximum device pressure exceeded 	811	Resistance on inspiration too high.	Reduce resistance and restart device. If alarm recurs: Contact your specialist dealer.
Maximum device pressure reached 	825	Resistance on inspiration too high.	Reduce resistance and restart device. If alarm recurs: Contact your specialist dealer.
HFT MODE ONLY			
Unable to reach flow. Check FiO ₂ , change flow setting or accessories. 	364	Set flow cannot be used.	Upper flow limit: Set a lower HFT flow and adjust O ₂ supply or use accessories with lower resistance. Lower flow limit: Set a higher HFT flow and adjust O ₂ supply or use accessories with higher resistance.
Disconnection patient 	465	Device operated with open patient/ventilator interface (mask not applied). Circuit is not connected to the device correctly or is not connected at all.	Check circuit, connections, and patient/ventilator interface at the patient.

8.5 Nurse call and remote alarm

For support in monitoring patient and device, especially in the case of life-support ventilation, the device has a remote alarm connection. All alarms are passed on to this connection.

In hospital, the device can be connected to the hospital's internal alarm system via the remote alarm connection.

In a domestic environment, you can connect the device to the VENTI*remote* alarm case via the remote alarm connection. The remote alarm case is for the remote transmission and amplification of the acoustic and visual alarm signals output by the device. Please also follow the instructions for use for the remote alarm connection and the associated cables.

9 Faults

FAULT	CAUSE	ACTION
No running noise, no display on screen.	No power supply present.	Check power cable is securely connected. Check function of socket.
Device does not reach set target pressure.	Coarse dust filter soiled.	Clean coarse dust filter. If necessary: Replace filter (see 6, p. 23).
	Breathing mask leaking.	Adjust headband so that the mask does not leak (see instructions for use for the mask). If necessary: Replace defective mask or patient/ventilator interface.
	Breathing circuit leaking.	Check circuit and eliminate leaks. If necessary: Replace circuit.
	Device defective.	Contact your specialist dealer.
Dark display does not react to display being touched. Display remains dark.	Device is switched off.	Switch on device (see 4.5, p. 15).
Device does not respond to display inputs.	Electronics in device have failed.	Restart device (hold down on/off key and alarm acknowledgement key simultaneously for 5 s).

10 Technical specifications

SPECIFICATION	DEVICE
Product class to MDR (EU) 2017/745	I Ib
Dimensions W x H x D in cm	30 x 13 x 21
Weight	3.8 kg
Temperature range - Operation - Transport and storage - Transport and storage at +70 °C - Transport and storage at -25 °C	+5 °C to +40 °C -25 °C to +70 °C Allow to cool to room temperature for 4 hours before starting up. Allow to heat to room temperature for 4 hours before starting up.
Permitted humidity for operation, transport, and storage	Relative humidity 10 % to 90 %, no condensation > 35 °C to 70 °C at a water vapor pressure up to 50 cmH ₂ O
Air pressure range	700 cmH ₂ O to 1100 cmH ₂ O, corresponds to an altitude of 3000 m above mean sea level
Diameter of circuit connection	Standard 22 mm tapered connector to ISO 5356-1
Maximum air flow at 20 cmH ₂ O	> 220 l/min
USB-C interface Maximum power output No power input	5 V/1.1 A
Power consumption on standby without battery charging Screen brightness 90 % Nurse call	230 VAC/0.07 A 48 VDC/0.3 A 24 VDC/0.61 A 12 VDC/1.21 A Maximum 60 VDC/1 A
Power consumption during ventilation without battery charging Screen brightness 90 % Ventilation settings: Mode: T Leakage circuit 15 mm Additional accessories: Breathing system filter, WilaSilent exhalation system IPAP: 40 EPAP: 4 F: 26.5 Ti: 1.1 Pressure rise: 1 Pressure drop: 1 Test lung bag	230 VAC/0.18 A 48 VDC/0.81 A 24 VDC/1.61 A 12 VDC/2.86 A
Electrical connection, device maximum Power supply unit Input voltage/maximum current Input frequency Output voltage/maximum current	48 VDC/2.7 A 24 VDC/5.4 A 12 VDC/7.0 A 100-240 VAC/2 A -1 A 50-60 Hz 48 VDC/2.7 A Tolerance -20 % + 10 %

SPECIFICATION	DEVICE
Internal/external battery Type Nominal capacity Nominal voltage Energy Typical discharge cycles	Li-ion 3200 mAh 29.3 V 93.7 Wh 500 charging cycles Battery capacity is reduced when the device is operated at low temperatures.
Operating hours of battery assuming following settings: Double circuit, PCV mode, $f=20/\text{min}$, $T_i=1\text{ s}$, PEEP=off, $V_t=800\text{ ml}$ Passive lung: Resistance $R = 5\text{ cmH}_2\text{O}/(\text{l/s})$; Compliance $C = 50\text{ ml}/\text{cmH}_2\text{O}$	$\geq 6\text{ hours}$
Duration of complete battery charge Duration of 80 % battery charge	$< 6\text{ hours}$ $< 5\text{ hours}$
Classification to IEC 60601-1-11: Class of protection against electric shock Degree of protection against electric shock Protection against harmful ingress of solids and water	Protection class II Type BF IP22
Classification to IEC 60601-1: Operating mode	Continuous duty
Application part	Patient/ventilator interface (e.g. mask, endotracheal tube, tracheostomy cannula), circuit, breathing system filter, SpO_2 sensor
Electromagnetic compatibility (EMC) to IEC 60601-1-2 Radio interference immunity	Medical electrical devices must only be installed and commissioned in a defined electromagnetic environment with regard to emission and radio interference immunity. More information, including test parameters and limit values, can be obtained from the manufacturer if required. EN 55011 B IEC 61000-4 Parts 2 to 6, Part 11, Part 8 IEC 61000-3 Parts 2 and 3
Heating of respiratory air	Maximum $+3\text{ }^\circ\text{C}$
Mean sound pressure level/operation to ISO 80601-2-72 at $\geq 500\text{ ml}$ at $\geq 150\text{ ml}$ at $\geq 30\text{ ml}$	38.5 dB(A) $\pm 3\text{ dB(A)}$, sound power level 46.5 dB(A) $\pm 3\text{ dB(A)}$ 37 dB(A) $\pm 3\text{ dB(A)}$, sound power level 45 dB(A) $\pm 3\text{ dB(A)}$ 41 dB(A) $\pm 3\text{ dB(A)}$, sound power level 49 dB(A) $\pm 3\text{ dB(A)}$
Sound pressure level of acoustic alarm to IEC 60601-1-8 for all alarm conditions (high, medium, low priority) Tolerance	Level 1 Low priority: 69 dB(A) Medium priority: 69 dB(A) High priority: 68 dB(A) $\pm 4\text{ dB(A)}$ Level 4 Low priority: 88 dB(A) Medium priority: 88 dB(A) High priority: 86 dB(A) $\pm 5\text{ dB(A)}$
IPAP pressure range	4 cmH_2O - 50 cmH_2O Most disadvantageous circuit for leakage ventilation: Circuit WM 29988, bacteria filter WM 27591 4 cmH_2O - 60 cmH_2O Most disadvantageous circuit for valve ventilation: Circuit LMT 31383, bacteria filter WM 27591
Accuracy of airway pressure	$\pm(2\text{ cmH}_2\text{O} + 4\text{ \% of the set value})$

SPECIFICATION	DEVICE
EPAP pressure range	4 cmH ₂ O - 25 cmH ₂ O
PEEP pressure range	Most disadvantageous circuit for leakage ventilation: Circuit WM 29988, bacteria filter WM 27591 0 cmH ₂ O - 25 cmH ₂ O Most disadvantageous circuit for valve ventilation: Circuit LMT 31383, bacteria filter WM 27591
Accuracy of airway pressure	±(2 cmH ₂ O + 4 % of the set value)
CPAP operating pressure range	4 hPa to 20 hPa
Tolerance	Most disadvantageous circuit for leakage ventilation: Circuit WM 29988, bacteria filter WM 27591 ±(2 cmH ₂ O + 4 % of the set value)
Pressure increment	0.2 cmH ₂ O
Maximum pressure in the event of a fault	≤ 90 cmH ₂ O
Respiratory frequency	2 - 60 bpm
Accuracy	± 0.5 bpm
Increment	0.5 bpm
Ti min, Ti max, Ti timed	0.5 s auto (Ti timed only) 0.05 s
Accuracy	0.05 s from 0.2 s to 0.8 s
Increment	0.1 s from 0.8 s to 4 s
Target volume (averaged over previous 5 breaths)	100 ml to 3000 ml
Accuracy of the volume measured by the ventilator ≥ 50 ml	± (4 ml + 15% of current value)
Increment	10 ml from 100 ml to 3000 ml
Area	0.1 l/min to 40 l/min
Trigger level	1 (high sensitivity) to 10 (low sensitivity) (step 1)
Inspiration	95 % to 5 % of maximum flow in 5 % increments
Exhalation	
Trigger device	The trigger on inspiration is triggered when patient flow exceeds the trigger threshold. The trigger on exhalation is triggered when patient flow on inspiration drops to the percentage value of maximum patient flow on inspiration.
I:E range (insp-exp. ratio)	1:59 to 2:1
Speed of pressure rise	Level 1: 100 cmH ₂ O/s Level 2: 80 cmH ₂ O/s Level 3: 50 cmH ₂ O/s Level 4: 20 cmH ₂ O/s
Speed of pressure rise MPV mode	Level 1: 60 cmH ₂ O/s Level 2: 45 cmH ₂ O/s Level 3: 30 cmH ₂ O/s Level 4: 15 cmH ₂ O/s
Speed of pressure drop (in leakage ventilation only)	Level 1: -100 cmH ₂ O/s Level 2: -80 cmH ₂ O/s Level 3: -50 cmH ₂ O/s Level 4: -20 cmH ₂ O/s
Maximum permitted flow for oxygen input	30 l/min
Permitted pressure	≤ 1000 cmH ₂ O
HFT flow range	5 l/min to 60 l/min
Increment	1 l/min
Tolerance	±(2 l/min +20 % of set value)
Fine filter up to 1 µm	Filter class E10 ≥ 99.5 %
up to 0.3 µm	≥ 85 %
Service life of fine filter	approx. 250 h

SPECIFICATION	DEVICE
USB flash drive	USB-C 3.0
Materials Housing Fine filter Coarse dust filter Circuit	Fire-retardant technical thermoplastics and silicones, stainless steel Polypropylene Polyurethane Polyethylene
Wireless module Frequency band Wireless standard	2.412 GHz to 2.4835 GHz ETSI EN 300 328
Filtering and smoothing techniques	The physiological alarms are triggered 3 breaths after the alarm threshold is reached. Exception: The Pulse high , Pulse low , SpO₂ high , and SpO₂ low alarms are triggered 15 seconds after the alarm threshold has been reached. The displays for pressure, flow, and leaks have low-pass filters.
Algorithm for alarm 758 (Constant pressure level)	Triggered when airway pressure is > 2 cmH ₂ O and remains continuously within a band of ±1 cmH ₂ O for at least 17 seconds
Breathing system filter	Dead space: 26 ml Flow resistance: 2.0 cm H ₂ O at 60 l/min
SpO ₂ sensor: - SpO ₂ display range • Increment • Accuracy • Data averaging • Data update Information on peak values of wavelengths, optical output power, and use • - Pulse display range • Increment • Accuracy • Data averaging • Data update	0 to 100% • 1% increments • See instructions for use for 8000SX sensor • Average over 4 beats • 1.5 seconds See instructions for use for 8000SX sensor 0 to 255 bpm • 1 bpm increments • See instructions for use for 8000SX sensor • Average over 4 beats • 1.5 seconds
SpO ₂ sensor alarms • SpO ₂ alarms preset • Pulse alarms preset • Delay of alarm condition • Delay of alarm generation	• 85 % • Off • 1.5 seconds • 15 seconds after alarm limit reached
The SpO ₂ sensors were validated and tested in line with EN ISO 80601-2-61.	
Service interval	4 years

TOLERANCES FOR MEASURING DEVICES USED

Pressure:	± 0.75 % of measured value or ± 0.1 cmH ₂ O
Flow:	± 2 % of actual value
Volume	± 3 % of actual value
Temperature:	± 0.3 °C
Time	±0.05 Hz/±0.001 bpm

All physiological flow and volume values are displayed in BTPS (patient flow, target volume, breath volume, minute volume). All other flow and volume values are displayed in STPD.

The right to make design modifications is reserved.

All parts of the device are free from latex.

Standard applied: EN ISO 80601-2-72: Particular requirements for the basic safety and essential performance of home ventilation devices for patients dependent on the device.

Devices of type LM150TD use software licensed under open source licenses. The source code of the corresponding software packages and the license texts as well as the SBOM and MDS2 documentation are available on request. Always keep the device software up to date to close security gaps and ensure the best protection.

11 Annex

11.1 Pneumatic diagram

11.1.1 Leakage circuit

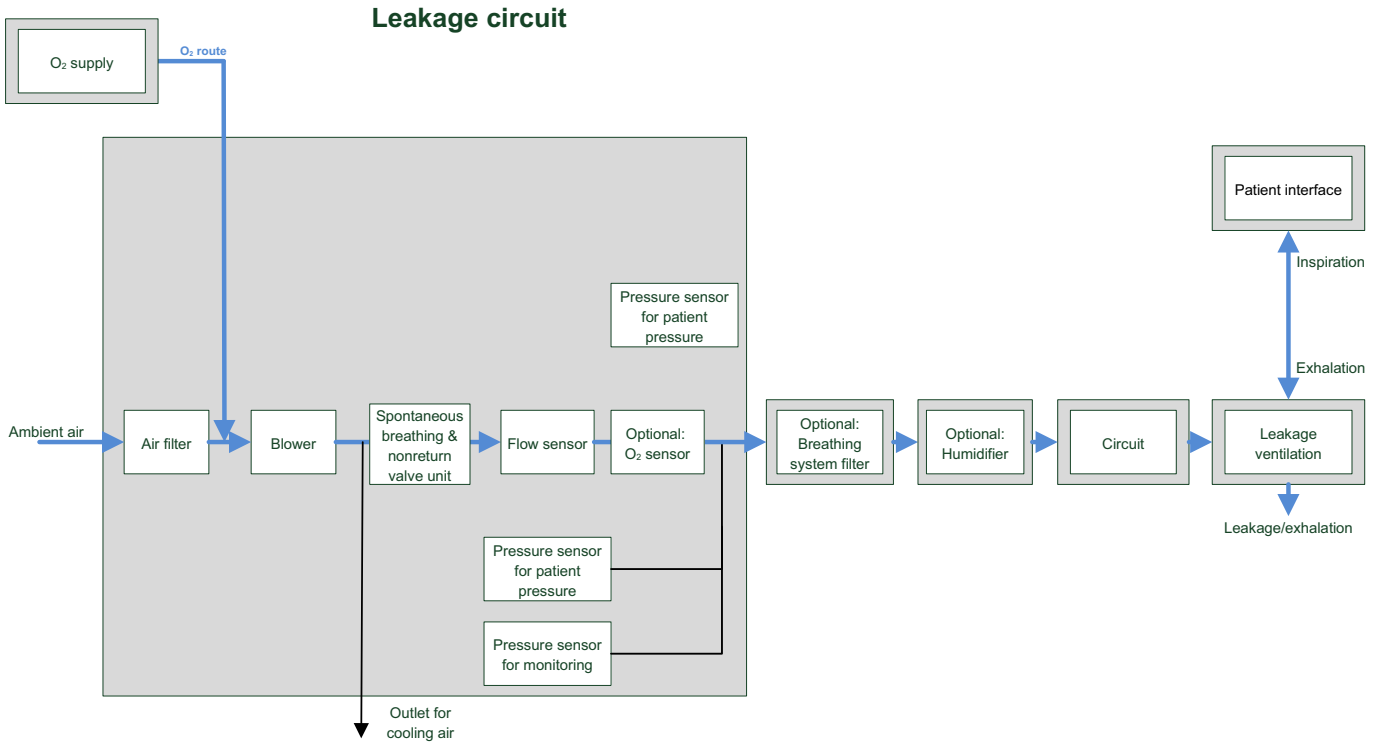

11.1.2 Single circuit with valve

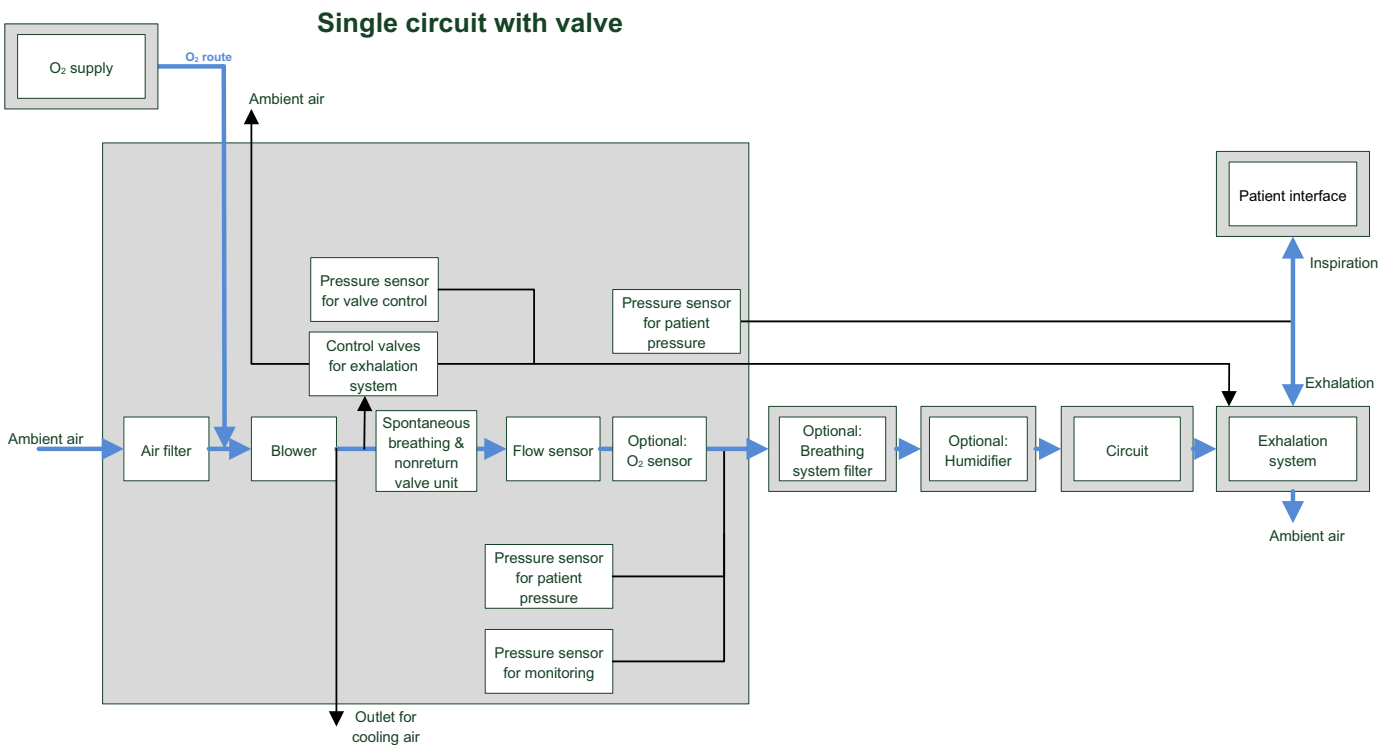

11.1.3 Double circuit

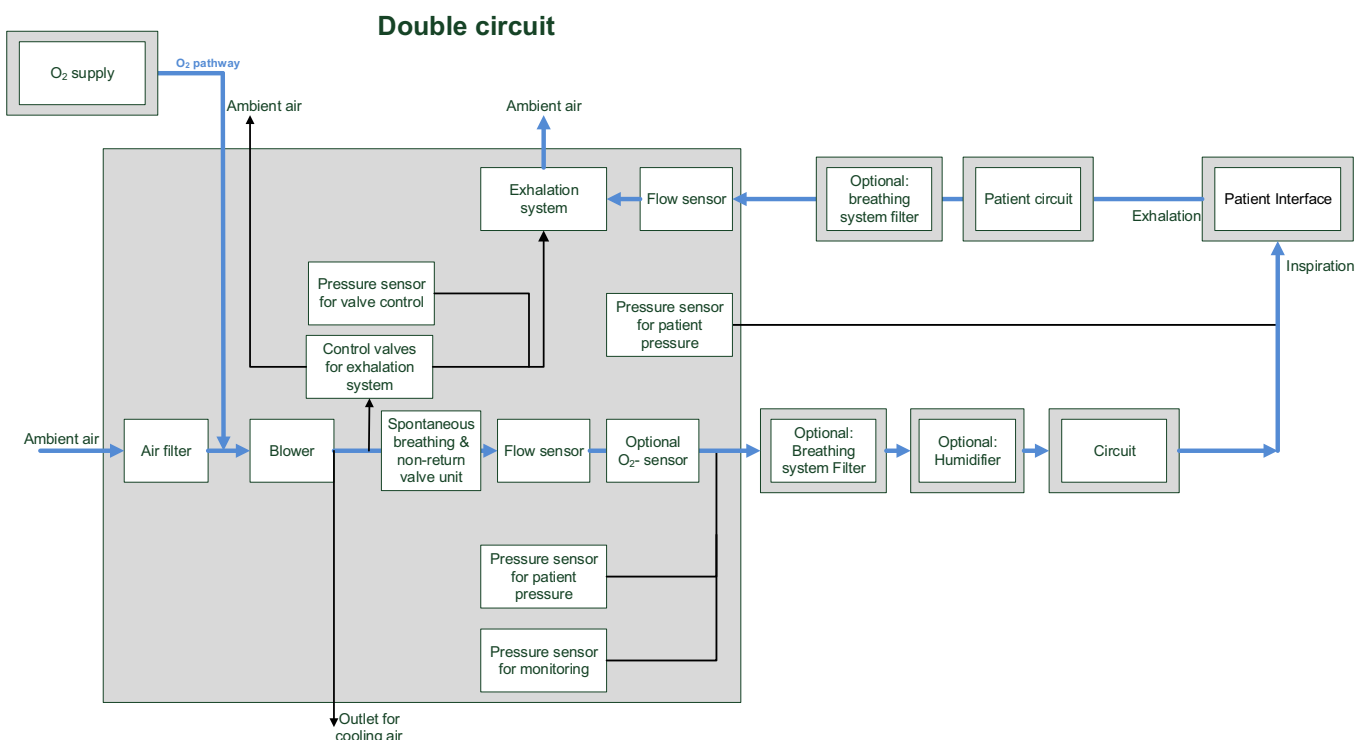

11.2 System resistances

The total pneumatic resistance of the connected circuit and of the connected accessories (e.g. humidifier, breathing system filter) between the device and the patient connection may not exceed the following value:

Circuits with a **diameter of 15 mm and 22 mm**:
Pressure drop ≤ 3.2 cmH₂O at a flow = 30 l/min (BTPS).

Circuits with a **diameter of 10 mm** (intended for volumes delivered of ≤ 50 ml): **Pressure drop ≤ 3.2 cmH₂O at a flow = 2.5 l/min (BTPS).**

The pressure drop values of the individual components can be added to form a total resistance value which must not exceed the value mentioned above.

Maximum error in pressure measurement:
 0.0125 cmH₂O

ARTICLE NUMBER	ARTICLE NAME	FLOW (BTPS) IN L/MIN	PRESSURE DROP IN CMH ₂ O
LMT 31382	LUISA, single circuit with valve, 180 cm, 22 mm Ø	30	0.11
LMT 31383	LUISA, single circuit with valve, 150 cm, 15 mm Ø	30	0.46
LMT 31384	LUISA, single circuit with valve, heated (i), autofill chamber, 150 cm + 60 cm, 15 mm Ø	30	2.04
WM 271704	LUISA, leakage circuit, heated (i), autofill chamber, passive valve, 150 cm + 60 cm, 15 mm Ø	30	2.03
WM 271705	LUISA, leakage circuit, heated (i), autofill chamber, passive valve, 150 cm + 60 cm, 22 mm Ø	30	0.31
LMT 31577	LUISA, double circuit, 150 cm, 15 mm Ø	30	Inspiration circuit: 0.76 Inspiration circuit from patient to device: 0.92 Exhalation circuit: 0.69
LMT 31581	LUISA, double circuit, 180 cm, 22 mm Ø	30	Inspiration circuit: 0.17 Inspiration circuit from patient to device: 0.24 Exhalation circuit: 0.17

ARTICLE NUMBER	ARTICLE NAME	FLOW (BTPS) IN L/MIN	PRESSURE DROP IN CMH ₂ O
LMT 31582	LUIISA, double circuit, heated (i+e), A-shaped adapter, autofill chamber, 150 cm + 60 cm, 15 mm Ø	30	Inspiration circuit: 2.03 Inspiration circuit from patient to device: 2.05 Exhalation circuit: 2.06
LMT 31383	LUIISA, double circuit, heated (i+e), A-shaped adapter, autofill chamber, 150 cm + 60 cm, 22 mm Ø	30	Inspiration circuit: 0.22 Inspiration circuit from patient to device: 0.32 Exhalation circuit: 0.37
LMT 31386	LUIISA, double circuit, heated (i+e), A-shaped adapter, autofill chamber, 120 cm + 60 cm, 10 mm Ø		Inspiration circuit: 0.17 Inspiration circuit from patient to device: 0.16 Exhalation circuit: 0.09
WM 27591	Teleflex Iso-Gard bacteria filter	2.5	0.06

11.3 Emission of electromagnetic interference

MEASUREMENTS OF INTERFERENCE EMISSION	COMPLIANCE
HF emissions to CISPR 11	Group 1/Class B
Harmonic distortion	Class A
Voltage fluctuations and flicker	Complies

11.4 Electromagnetic interference immunity















INTERFERENCE IMMUNITY TESTS	COMPLIANCE LEVEL
Discharge of static electricity (ESD) to IEC 61000-4-2	± 8 kV contact discharge ± 15 kV air discharge
Radiated HF interference to IEC 61000-4-3	3 V/m 80 MHz to 2.7 GHz
Test specifications for the interference immunity of sheathing to high-frequency wireless communication equipment IEC 61000-4-3	Table 9 of EN 60601-1-2:2014
Electrical fast transients/bursts to IEC 61000-4-4	± 2 kV for power supply cables ± 1 kV for input and output lines
Surge immunity to IEC 61000-4-5	± 1 kV line to line ± 2 kV line to ground
Conducted HF interference to IEC 61000-4-6	3 Vrms 150 KHz to 80 MHz 6 Vrms in ISM frequency bands between 150 kHz and 80 MHz
Magnetic field at the power supply frequency (50/60 Hz) to IEC 61000-4-8	30 A/m
Voltage dips/short interruptions and variations in power supply to IEC 61000-4-11	0 % UT; 250/300 periods









Key performance characteristics of the device as per ISO 80601-2-72

- Accuracy of airway pressure
- Accuracy of the volume delivered in a single breath
- No faulty setting of ventilation parameters
- Functionality of alarms

11.5 Markings and symbols

The following symbols may be applied to the device, the device ID plate, accessories or packaging.

SYMBOL	DESCRIPTION
	Pressure measuring tube connection
	Valve control tube connection
	Patient's exhaled air outlet on double circuit; do not block outlet
	Inlet; do not block openings
	Outlet
	Follow instructions for use
	Direct current: 12 V, 24 V or 48 V
TYPE:	Type designation of the device
	Order number
	Suitable for use in commercial aircraft. Meets RTCA/DO-160G Section 21, Category M.
	Unique device identifier (uniform product code for medical devices)
	Serial number
	Degree of protection against electric shock: Protection class II product
	Do not dispose of the product in domestic waste
	Follow the instructions for use
IP22	Degree of protection against contact with a finger. Protection against vertically falling water drops when enclosure tilted up to 15°.
	Type BF application part

SYMBOL	DESCRIPTION
	Manufacturer and, if necessary, date of manufacture
	Indicates the product is a medical device
	Permitted temperature range for transport and storage
	Permitted humidity range for transport and storage
	Protect from moisture
	Fragile. Do not throw or drop
	Federal law restricts this device to sale by or on the order of a physician
	Use multiple times on a single patient

11.6 Scope of delivery for LMT 31390US-1110 LUISA with HFT mode

The parts below are included in the standard scope of delivery:

PART	ARTICLE NUMBER
Basic device with HFT mode	LMT 31470
Exhalation module (disposable)	LMT 31425
Leakage circuit, 22 mm Ø	LMA 91113
Power supply unit	LMT 31569
Power cord	WM 27027
Oxygen connecting bushing	WM 30669
Set, 12 fine filters	WM 29652
Set, 2 coarse dust filters	WM 29928
Protective bag	LMT 31417
Bag pendant	LMT 31408
USB flash drive	LMT 31414
Set, LUISA documents	LMT 15996US0
Final inspection log	LMT 31588
Accessories bag	LMT 31440

11.7 Accessories

PART	ARTICLE NUMBER
Teleflex Iso-Gard breathing system filter	WM 27591
FiO ₂ cell, complete	LMT 31502
Leakage exhalation valve	LMA 91115
Single circuit with valve, 15 mm Ø	LMA 91102
Single circuit with valve, 22 mm Ø	LMA 91101
Double circuit, 15 mm Ø	LMA 91103
Double circuit, 22 mm Ø	LMA 91104
Leakage circuit, 15 mm Ø	LMA 91112
Leakage circuit, 22 mm Ø	LMA 91113
Leakage circuit, 22 mm Ø with breathing system filter and leakage exhalation valve	LMA 91106
Leakage circuit, 22 mm Ø without breathing system filter and with leakage exhalation valve	LMA 91107
Leakage circuit, 15 mm Ø with breathing system filter and with leakage exhalation valve	LMA 91108
Leakage circuit, 15 mm Ø without breathing system filter and with leakage exhalation valve	LMA 91109
Leakage circuit, mouthpiece ventilation 15 mm Ø	WM 27651
Heated circuit	LMA 91116
prismaVENT Aqua 115V	LMA 91120
Mobility bag	LMT 31554
Trolley 2.0	LMT 31355
Power supply unit clamp for trolley 2.0	LMT 31351
Water bag holder for trolley 2.0	LMT 31353
Oxygen cylinder clamp for trolley 2.0	LMT 31352
Hinged arm for trolley	LMT 31354
Set, LUISA mounting plate	LMT 31359
Set, LUISA plate for trolley 2.0	LMT 31371
Wall clamp for ISO rail	LMT 31368
Exhalation module (disposable)	LMT 31404
Exhalation module (autoclavable)	LMT 31413
External battery	LMT 31540
Battery charger	LMT 31594US
VENTIremote alarm, 10 m	LMT 31560
VENTIremote alarm, 30 m	LMT 31570
Cable, 10 m, nurse call for LUISA	LMT 31510
Cable, 30 m, nurse call for LUISA	LMT 31520
CD-ROM with prismaTS software	WM 93331
USB flash drive	LMT 31414
COM cable for monitor	LMT 31578

PART	ARTICLE NUMBER
Set, 90° circuit adapter	LMT 15984
SpO ₂ sensor, size S	LMT 31580
SpO ₂ sensor, size M	LMT 31396
SpO ₂ sensor, size L	LMT 31388
Cable, SpO ₂ /Xpod sensor	LMT 31593
USB modem	LMT 31763NAM0

11.8 Removable parts

PART	ARTICLE NUMBER
Filter holder	LMT 31422
Exhalation module cover	LMT 31481
Exhalation module (disposable)	LMT 31425
Set, exhalation module (can be subjected to hygiene treatment)	LMT 15961
Exhalation module orifice	LMT 31574

11.9 Limited Warranty

Loewenstein Medical Americas Corp. (Loewenstein Medical) warrants that your product will be free from defects of workmanship and materials and will perform in accordance with the product specifications for the respective warranty period (the Warranty Period) specified for each product below (the Limited Warranty).

PRODUCT	WARRANTY PERIODS
Devices including accessories (Exception: Masks)	2 years
Masks including accessories, batteries, sensors, circuits	6 months
Single use products	No warranty

This Limited Warranty gives you specific legal rights, and you may also have other rights which vary from state to state. This Limited Warranty is given in lieu of all other express warranties. You are cautioned that no person or entity is authorized to make any warranties on behalf of Loewenstein Medical, and any such alleged warranties are hereby disclaimed by Loewenstein Medical.

WHAT DOES THIS WARRANTY NOT COVER?

This Limited Warranty does not cover any damage due to: (a) transportation; (b) storage; (c) improper use; (d) any damage caused by exposure to ozone, activated oxygen or other gases; (e) failure to follow the product instructions or perform preventive maintenance or regular cleaning; (f) modifications; (g) unauthorized repair; (h) normal wear and tear; (i) any damage or contamination due to cigarette, pipe, cigar or other smoke; (j) environmental conditions (including but not limited to water, flame, chemicals, fumes in the atmosphere, extreme heat or cold, food or liquid, sand, dirt or the like); (k) damage during the return merchandise authorization process; or (l) external causes such as accidents, abuse, or other actions or events beyond Loewenstein Medical's reasonable control.

WHAT IS THE PERIOD OF COVERAGE?

This Limited Warranty lasts for the corresponding Warranty Period indicated in the table above from the date of shipment by Loewenstein Medical to the original purchaser. To the full extent permitted under applicable law, the Warranty Period or coverage will not be extended or renewed or otherwise affected due to Loewenstein Medical's authorized repair or replacement. However, product(s) repaired or replaced will be warranted for the unexpired portion of the original Limited Warranty. Loewenstein Medical reserves the right to charge dealers for warranty service of failed product not purchased directly from Loewenstein Medical or authorized distributors. Loewenstein Medical may change the availability of this Limited Warranty at its discretion, but any changes will not be retroactive.

WHAT ARE YOUR REMEDIES UNDER THIS WARRANTY?

If a product fails under conditions of normal use during the Warranty Period, Loewenstein Medical will, in its sole discretion: (a) repair or replace such product (or the defective part) free of charge or (b) refund the purchase price of such product in lieu of its repair or replacement. The choice of repair, replacement or refund by Loewenstein Medical will be your sole and exclusive remedy. Loewenstein Medical will pay for shipping and handling fees to return the repaired or replacement product to you if Loewenstein Medical elects to repair or replace the defective product. Loewenstein Medical shall examine any product(s) returned for service, and Loewenstein Medical reserves the right to charge an evaluation fee for any returned device as to which no problem is found after its investigation. LOEWENSTEIN MEDICAL MUST AGREE THAT THE PRODUCT IS DEFECTIVE.

HOW DO YOU OBTAIN WARRANTY SERVICE?

To obtain Limited Warranty service, contact your Loewenstein Medical Dealer.

LIMITATION OF LIABILITY

EXCEPT AS SET FORTH IN THIS LIMITED WARRANTY, LOEWENSTEIN MEDICAL MAKES NO WARRANTIES, EXPRESSED OR IMPLIED, STATUTORY OR OTHERWISE, REGARDING THE PRODUCT, ITS QUALITY OR PERFORMANCE. THE LIMITED WARRANTY REPLACES ALL OTHER EXPRESSED OR IMPLIED WARRANTIES, INCLUDING ANY IMPLIED WARRANTIES OF MERCHANTABILITY AND FITNESS FOR A PARTICULAR PURPOSE, AND LOEWENSTEIN MEDICAL SPECIFICALLY LIMITED SUCH IMPLIED WARRANTIES TO THE DURATION OF THE APPLICABLE WARRANTY PERIOD.

THE REMEDIES DESCRIBED ABOVE ARE YOUR SOLE AND EXCLUSIVE REMEDIES AND LOEWENSTEIN MEDICAL'S ENTIRE LIABILITY FOR ANY BREACH OF THIS LIMITED WARRANTY. LOEWENSTEIN MEDICAL'S RESPONSIBILITY FOR DEFECTIVE PRODUCTS IS LIMITED TO REPAIR, REPLACEMENT OR REFUND AS DESCRIBED ABOVE IN THIS LIMITED WARRANTY. LOEWENSTEIN MEDICAL'S LIABILITY SHALL UNDER NO CIRCUMSTANCES EXCEED THE PRICE PAID TO LOEWENSTEIN MEDICAL BY THE ORIGINAL PURCHASER FOR THE PRODUCT, NOR SHALL LOEWENSTEIN MEDICAL UNDER ANY CIRCUMSTANCES BE LIABLE FOR THE COST OF PROCUREMENT OF SUBSTITUTE PRODUCTS OR FOR ANY CONSEQUENTIAL, EXEMPLARY, INCIDENTAL, SPECIAL OR PUNITIVE DAMAGES OR LOSSES, WHETHER DIRECT OR INDIRECT (INCLUDING, BUT NOT LIMITED TO, COMMERCIAL LOSS OR LOST REVENUES), FOR ANY CAUSE OF ACTION, WHETHER IN CONTRACT OR TORT, AND WHETHER OR NOT LOEWENSTEIN MEDICAL WAS AWARE OR SHOULD HAVE BEEN AWARE OF THE POSSIBILITY OF THESE DAMAGES.

SOME STATES DO NOT ALLOW THE EXCLUSION OR LIMITATION OF INCIDENTAL OR CONSEQUENTIAL DAMAGES, SO THE ABOVE LIMITATION OR EXCLUSION MAY NOT APPLY TO YOU.

LMT 68541g 04/2026 EN_US

Manufactured for:
**Loewenstein Medical
Americas Corp.**
4080 McGinnis Ferry Rd, Suite 1303
Alpharetta, GA 30005
United States of America

LÖWENSTEIN
medical